

Dual Band 2.45 GHz and GNSS RF Chip Antenna

- 2.4 – 2.5 and 1.561/1.575/1.602 GHz pass band
- Bluetooth, Wi-Fi, GPS/BDS/GLONASS
- SMD, (10x3.2x1.5mm)
- Mid-edge mount, dual feed (separate frequency feeds)
- RoHS compliant and AEC-Q200 Qualified

Johanson Technology, Inc. (JTI) miniature RF ceramic chip antennas are made using Low Temperature Co-fired Ceramic (LTCC) technology which has the ability to embed low and high dielectric constants inside our antenna. This enables our components to have high detuning resilience and stability over extreme temperatures (~2ppm).

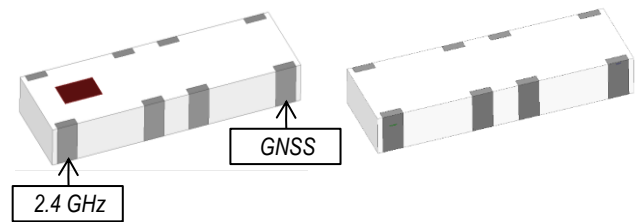

Recommended mounting locations for this antenna

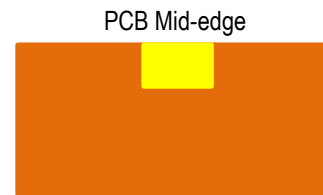

General Specifications^{1 2}

Passband Frequency (MHz)	2400 - 2500	1561	1575	1602
Impedance (Ω)	50	50	50	50
Return Loss (dB)	7.36 Min.	7.36 Min.	7.36 Min.	7.36 Min.
Peak Gain (dBi)	1.0 Typ.	0.5 Typ.	1.0 Typ.	0.5 Typ.
Average Gain (dBi)	-1.0 Typ.	-2.0 Typ.	-2.0 Typ.	-3.0 Typ.
Isolation (dB)	20	15	15	15
Average Radiated Efficiency (%)	79	47	50	41

Maximum Ratings

Power Capacity (W)	2 Max. (CW)
Operating Temperature ($^{\circ}\text{C}$)	-40 to +105
Recommended Storage Conditions post-installation ($^{\circ}\text{C}$)	-40 to +105
Recommended Storage Conditions and Period for Unused T&R Product	45% - 75% RH +5 to +35 $^{\circ}\text{C}$ 18 Months Max.

¹ Typical value represents average measurement at 25 $^{\circ}\text{C}$. Min./Max. values represent measurements over specified operating temperature.

² General specifications measured on Johanson's evaluation board P/N 0900AD47A2450001CE1.

Mechanical Dimensions

	Inches			Millimeters		
L	0.394	±	0.008	10.00	±	0.20
W	0.126	±	0.008	3.20	±	0.20
T	0.059	±	0.008	1.50	±	0.20
a1	0.031	±	0.008	0.80	±	0.20
a2	0.106	±	0.008	2.70	±	0.20
a3	0.039	±	0.008	1.00	±	0.20
b	0.012	+0.004/-0.008		0.30	+0.10/-0.20	

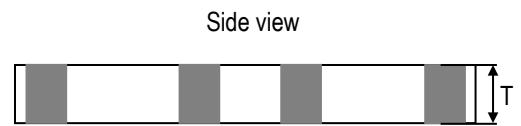
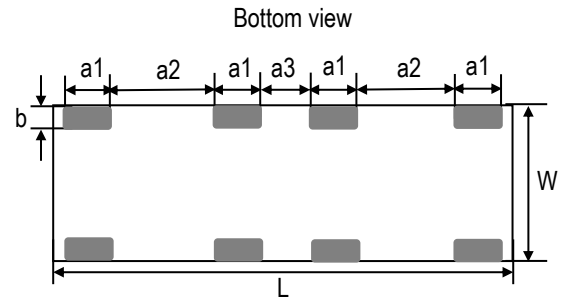

Terminal Configuration ³

Pin Number	Function
1	2.4 GHz Feed
2	GND
3	GND
4	GNSS Feed
5	GND
6	GND
7	GND
8	GND

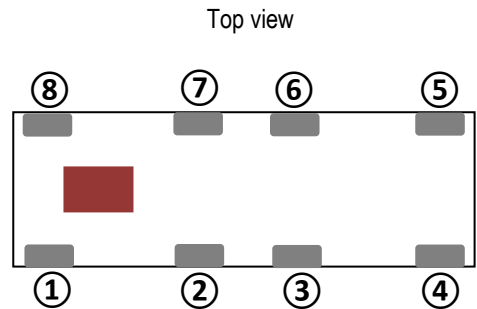

³ The termination type is Nickel Tin. Go to: <https://www.johansontechnology.com/ipcsoldering-profile> for Typical Soldering Profile.

Evaluation Board and Recommended Mounting Configuration (P/N 2450AD47A1590001CE1)

All units in mm

Top View

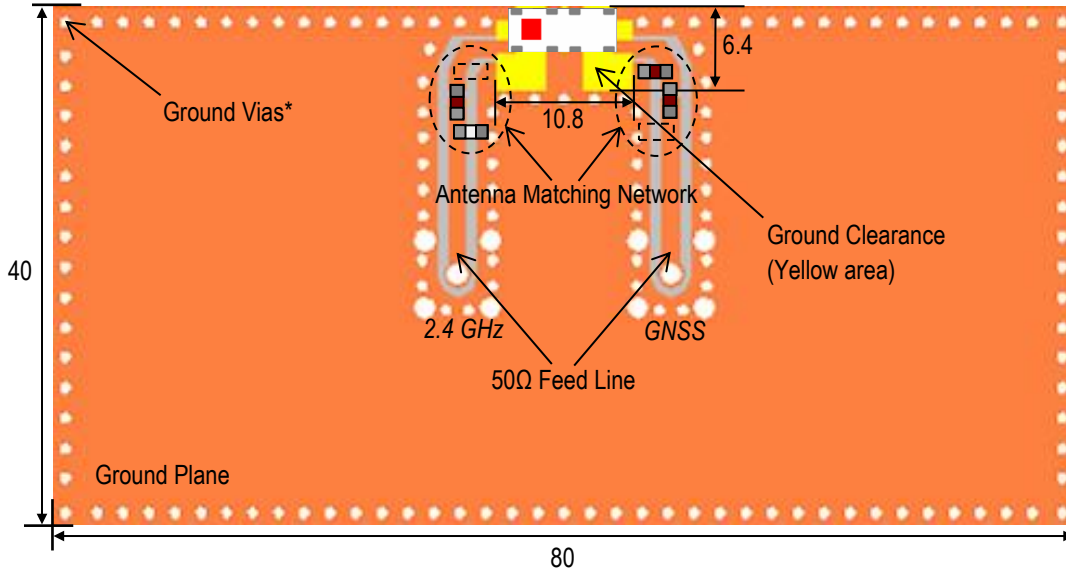

Bottom View

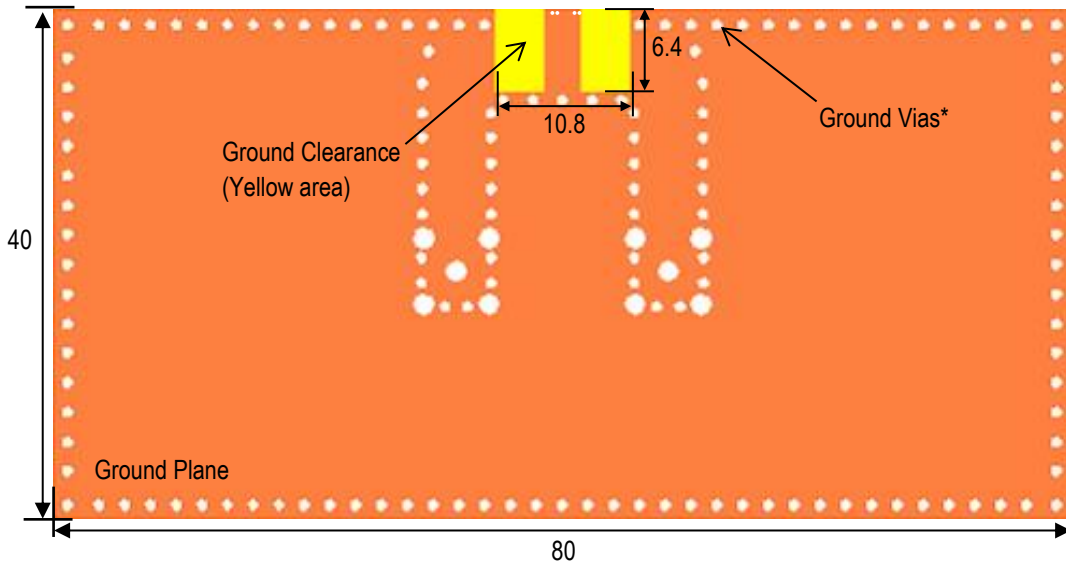

*Note: Ground Vias are highly recommended to have better antenna efficiency.

Evaluation Board and Recommended Mounting Configuration (continued)

All units in mm

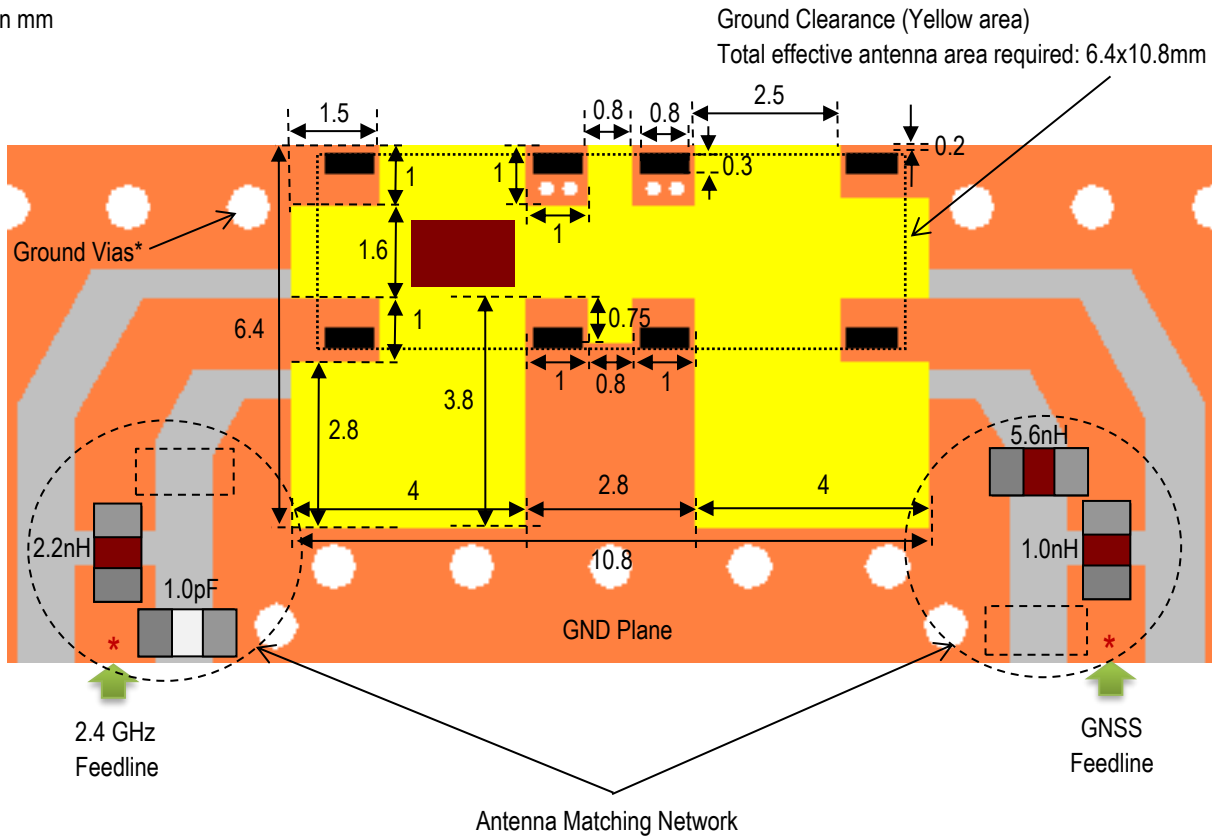

JTI P/Ns for Matching Network⁴

Inductor (2.2nH): LRC0402CS2N2GV001T

Capacitor (1.0pF): QSCF500Q1R0B1GV001T

Inductor (5.6nH): LRC0402CS5N6GV001T

Inductor (1.0nH): LRC0402CS1N0GV001T

* Transmission line width should be designed to match 50Ω characteristic impedance, depending on PCB material and thickness, and preferably CPWG (co-planar wave guide) type.

*Note: Ground Vias are highly recommended to have better antenna efficiency.

If you'd like the CAD PCB layout or have any questions,
contact our application engineers at <https://www.johansontechnology.com/ask-a-question>

⁴ It is recommended that the designer leave available slots for the topology of the network. The antenna matching network values above are used when the antenna is mounted on Johanson's evaluation board. The optimal matching values will vary depending on the layout, thickness, material, etc. Go to: <https://www.johansontechnology.com/tuning> for more information.



Evaluation Board Typical Return Loss Measurement (P/N 2450AD47A1590001CE1)

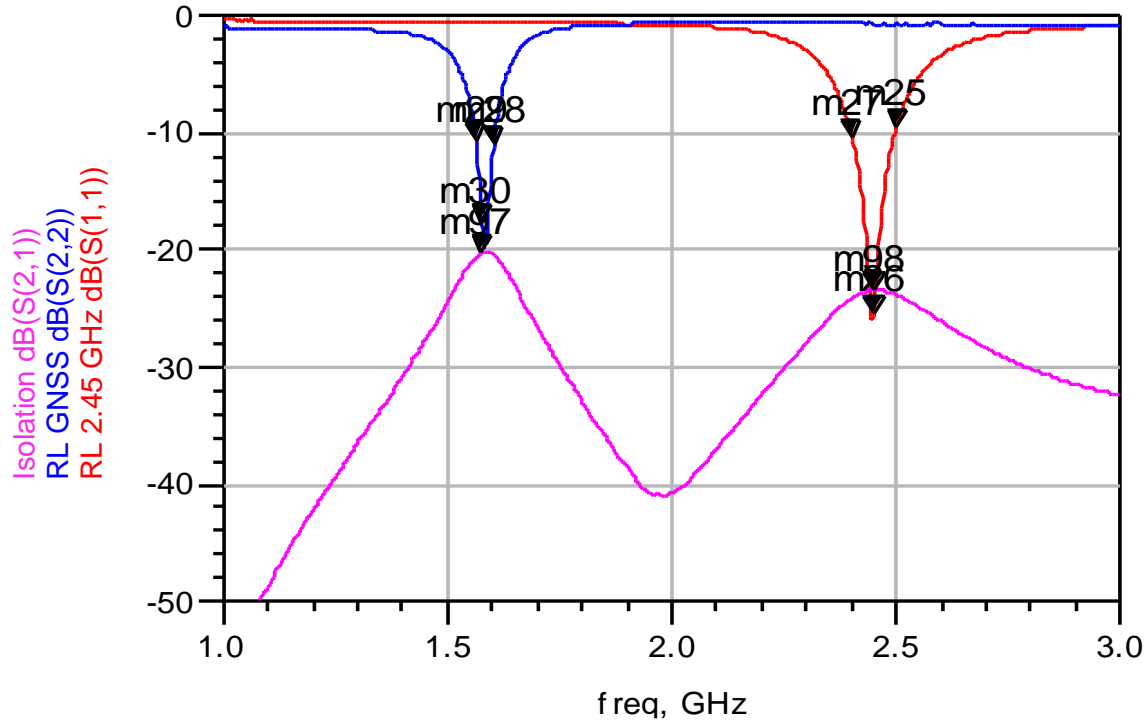

m29 freq=1.561GHz dB(S(2,2))=-10.712	m27 freq=2.400GHz dB(S(1,1))=-10.278
--	--

m30 freq=1.575GHz dB(S(2,2))=-17.685	m26 freq=2.450GHz dB(S(1,1))=-25.308
--	--

m28 freq=1.602GHz dB(S(2,2))=-10.900	m25 freq=2.500GHz dB(S(1,1))=-9.508
--	---

m97 freq=1.575GHz dB(S(2,1))=-20.300	m98 freq=2.450GHz dB(S(2,1))=-23.468
--	--

Evaluation Board Typical 2D Radiation Patterns (P/N 2450AD47A1590001CE1)

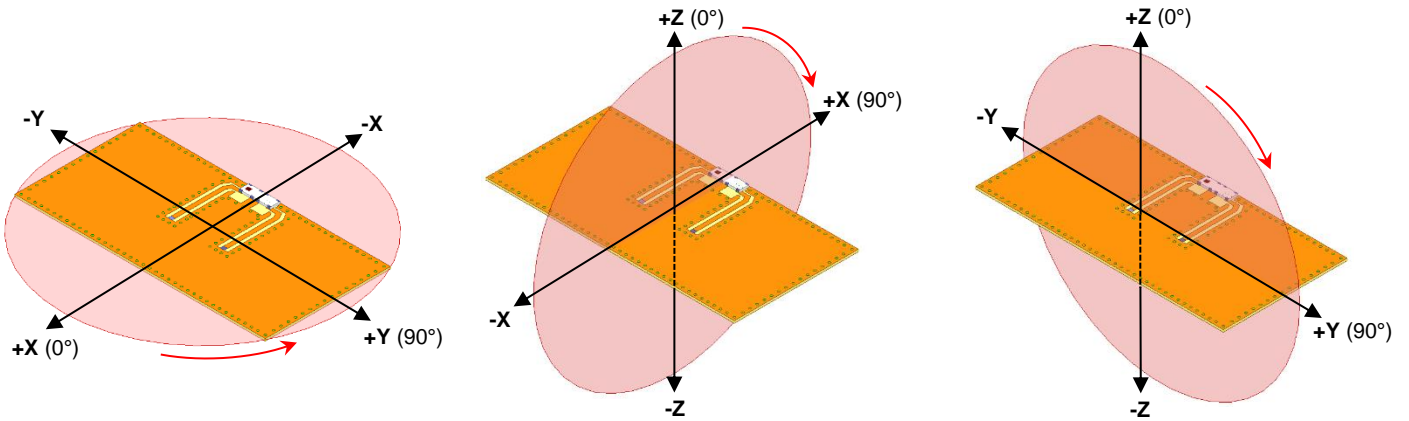

@2450MHz Band

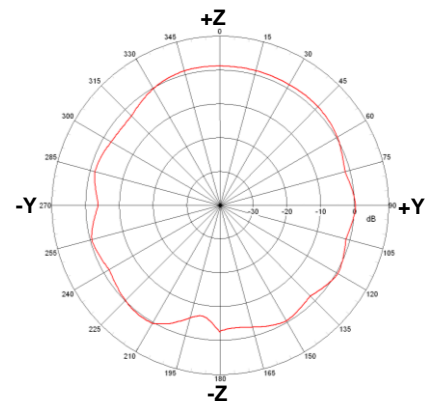
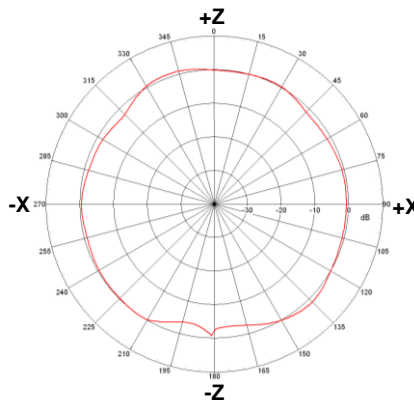
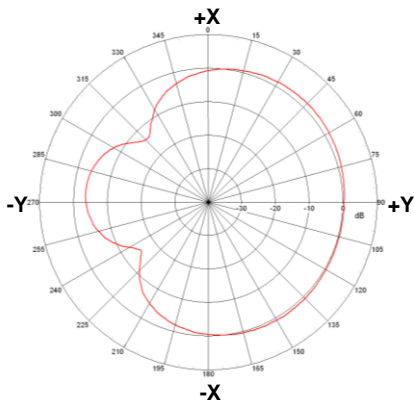

@1561MHz Band

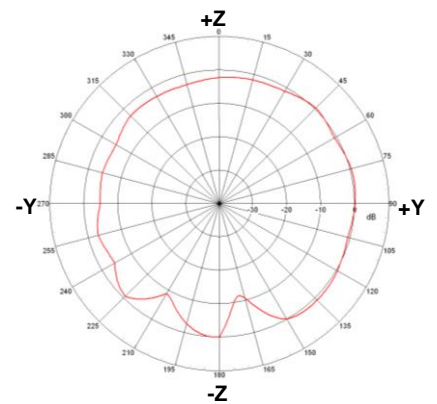
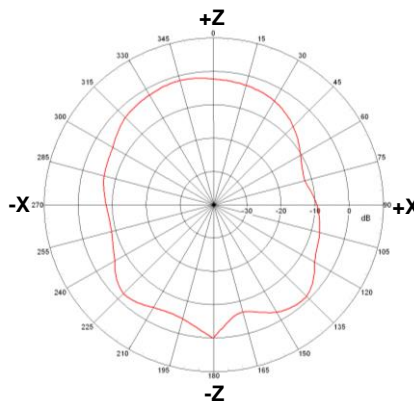
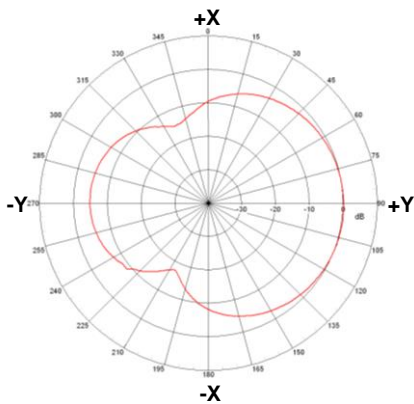

@1575MHz Band

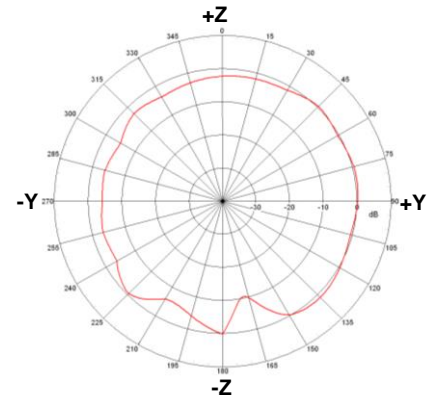
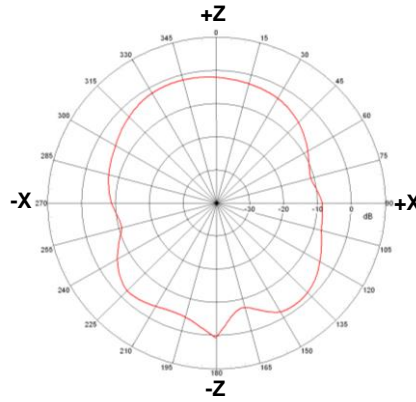
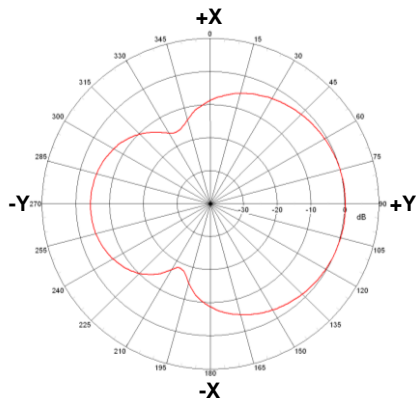

@1602MHz Band

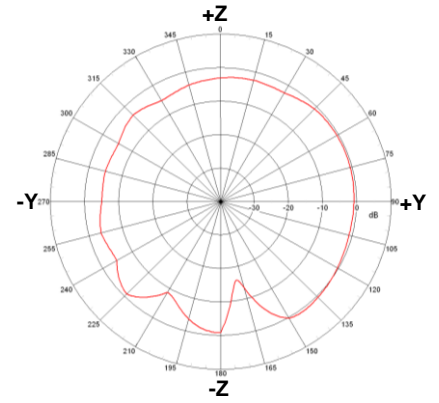
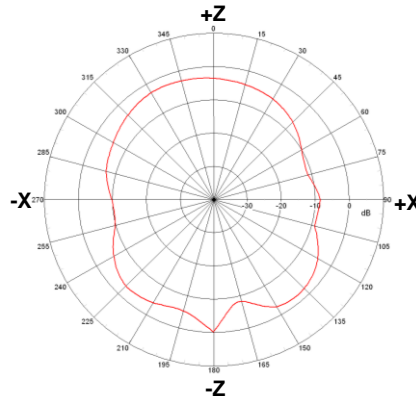
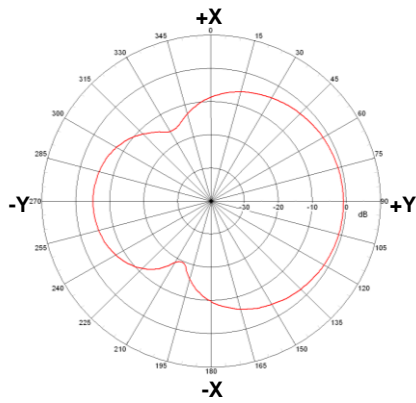

Tape and Reel Specification (Units in mm)

Tape Dimensions

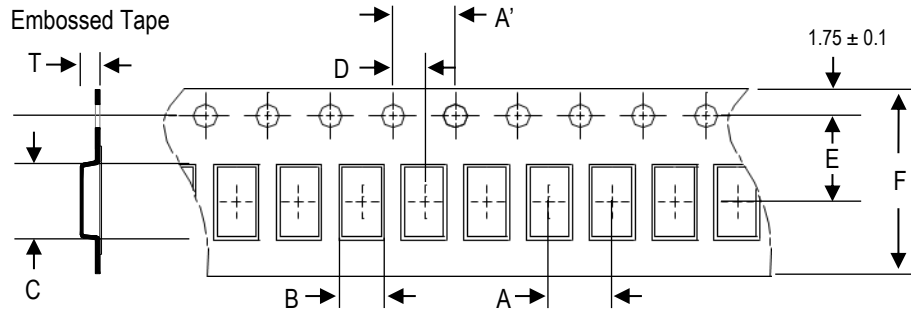

A	A'	B	C	D	E	F	T	Quantity/reel	Tape material
8.0±0.1	4.0±0.1	3.45±0.1	10.3±0.1	2.0±0.05	7.5±0.1	16.0±0.2	1.7±0.1	1,000pcs.	Plastic (Embossed)

Reel Dimensions

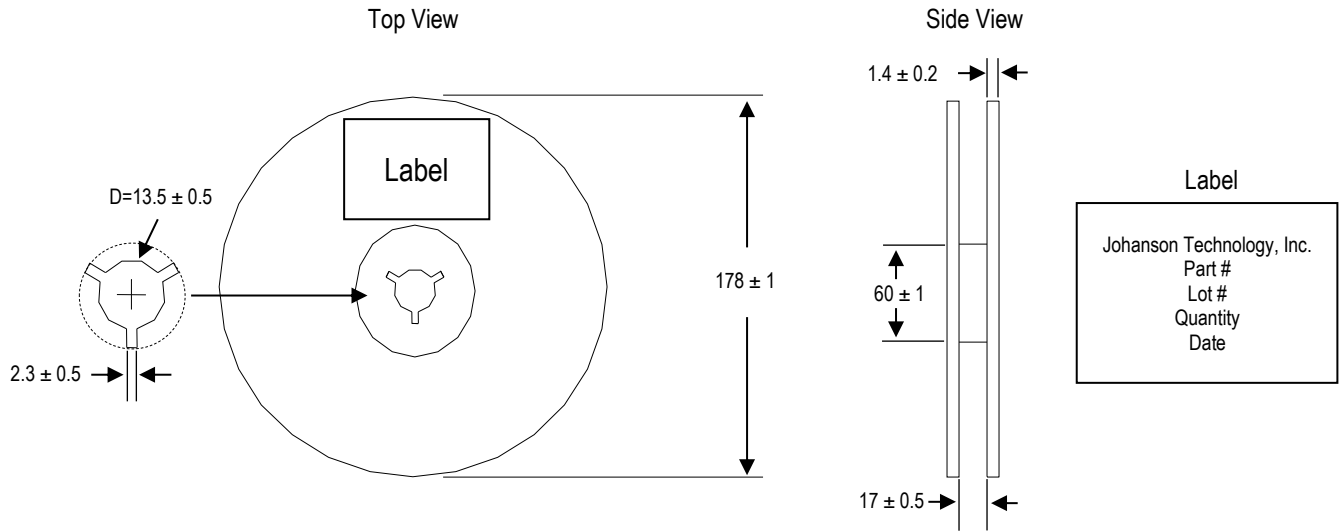

Leader and Trailer Dimensions

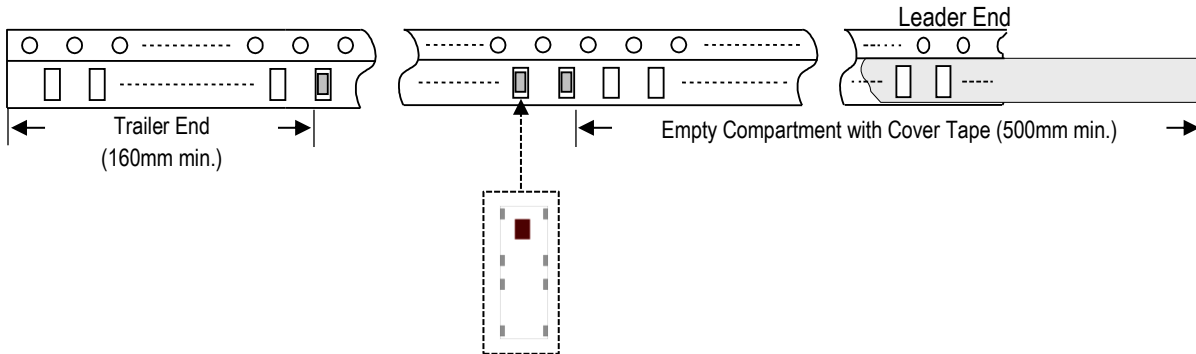

Orderable Part Number

Packaging Style	Part Number	Termination
Bulk (loose pcs.)	2450AD47A1590002B	Nickel Tin
T & R (7" Reel Embossed Tape)	2450AD47A1590002E (Qty: 1,000 pcs./reel)	
Evaluation Board with 2 SMA Connector	2450AD47A1590001CE1	

Important Links

[2450AD47A1590002E Product Page](#)

[More RF Chip Antennas](#)

[Antenna Tuning, Optimization, and Validation Services](#)

[Soldering Information](#)

[MSL Information](#)

[Packaging Information](#)

[Recommended Storage Condition and Max Shelf Life](#)

[RoHS Compliance](#)

Contact our application engineers for a PCB layout review.

**Johanson Technology, Inc. reserves the right to make design changes without notice.
All sales are subject to Johanson Technology, Inc. terms and conditions.**