

## 2.45 GHz RF Chip Antenna

- 2.4 – 2.5 GHz pass band
- Bluetooth, WLAN
- SMD, 5.0x2.0x1.1mm (LxWxT)
- Corner mount
- RoHS compliant

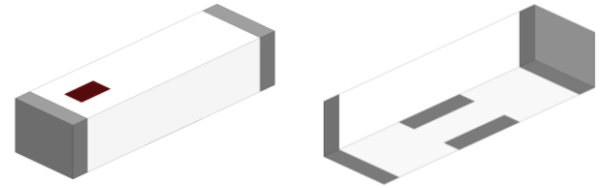

Johanson Technology, Inc. (JTI) miniature RF ceramic chip antennas are made using Low Temperature Co-fired Ceramic (LTCC) technology which has the ability to embed low and high dielectric constants inside our antenna. This enables our components to have high detuning resilience and stability over extreme temperatures (~2ppm).

Recommended mounting locations for this antenna

PCB Corner



### General Specifications<sup>1 2</sup>

Passband Frequency (MHz)	2400 - 2500
Impedance ( $\Omega$ )	50
Return Loss (dB)	9.5 Min.
Peak Gain (dBi)	1.2 Typ.
Average Gain (dBi)	-0.6 Typ.
Average Radiated Efficiency (%)	55

### Maximum Ratings

Power Capacity (W)	3 Max. (CW)
Operating Temperature ( $^{\circ}\text{C}$ )	-40 to +125
Recommended Storage Conditions post-installation ( $^{\circ}\text{C}$ )	-40 to +125
Recommended Storage Conditions and Period for Unused T&R Product	45% - 75% RH +5 to +35 $^{\circ}\text{C}$ 18 Months Max.

<sup>1</sup> Typical value represents average measurement at 25 $^{\circ}\text{C}$ . Min./Max. values represent measurements over specified operating temperature.

<sup>2</sup> General specifications measured on Johanson's evaluation board P/N 2450AT42B0100001CE1.

**Mechanical Dimensions**

	Inches			Millimeters		
<b>L</b>	0.197	±	0.008	5.00	±	0.20
<b>W</b>	0.079	±	0.008	2.00	±	0.20
<b>T</b>	0.079	+0.004/-	0.008	2.00	+0.1/-	0.2
<b>L1</b>	0.102	±	0.008	2.60	±	0.20
<b>W1</b>	0.020	±	0.008	0.50	±	0.20
<b>a</b>	0.020	±	0.012	0.50	±	0.30

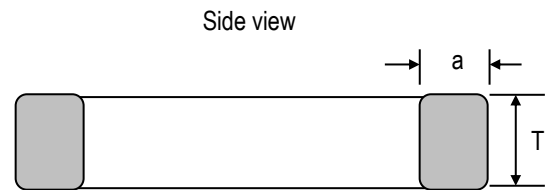
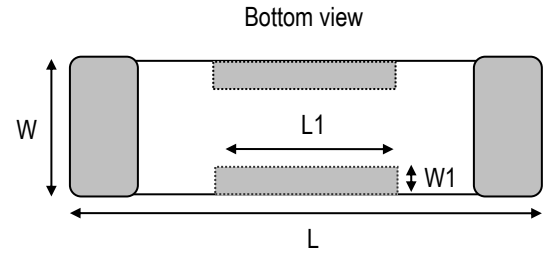

**Terminal Configuration<sup>3</sup>**

Pin Number	Function
1	Feed
2	NC*
3	NC*
4	NC*

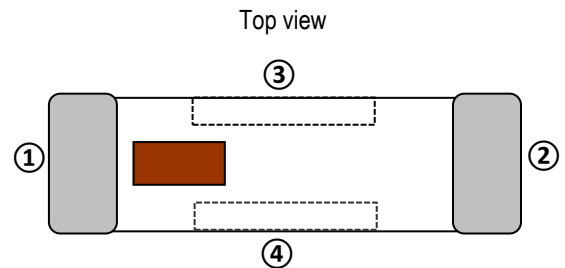

<sup>3</sup> The termination type is Nickel Tin. Go to: <https://www.johansontechnology.com/ipcsoldering-profile> for Typical Soldering Profile.

\* This terminal must be soldered for anchoring and mechanical stability.



**Evaluation Board Typical Return Loss Measurement (P/N 2450AT42B0100001CE1)**

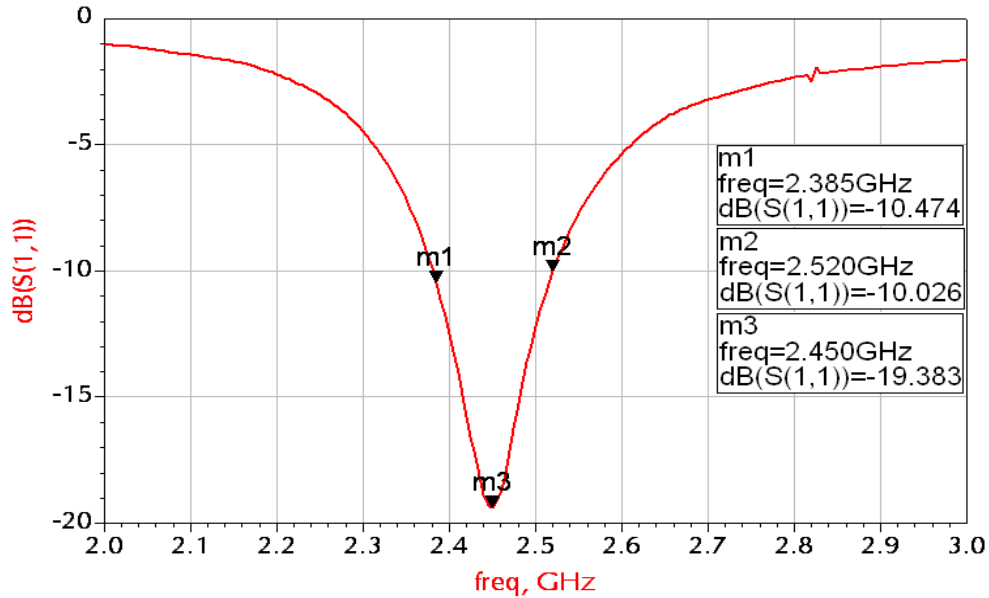

**Evaluation Board Typical 2D Radiation Patterns @2450MHz (P/N 2450AT42B0100001CE1)**

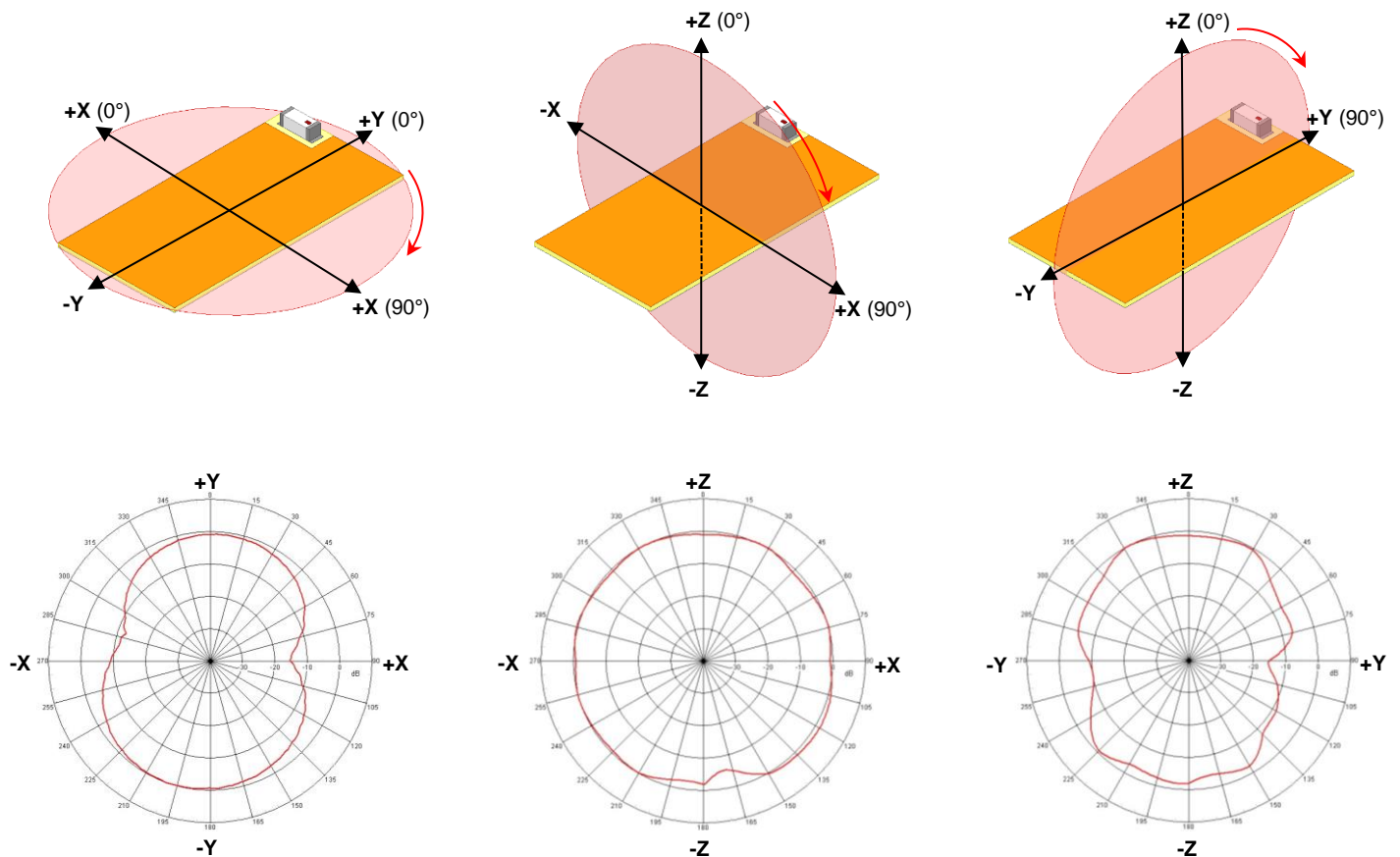

**Tape and Reel Specification (Units in mm)**

**Tape Dimensions**

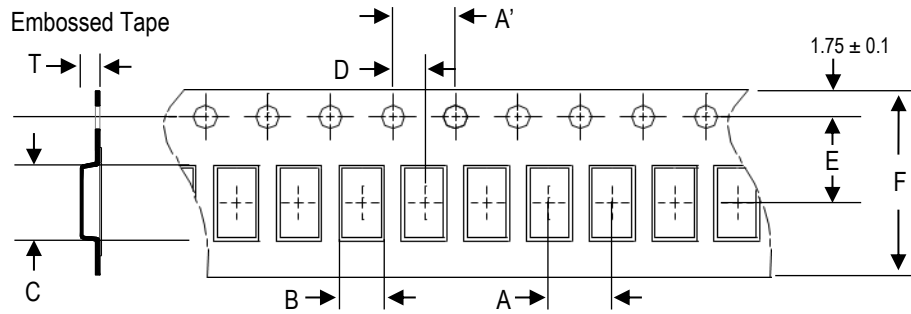

A	A'	B	C	D	E	F	T	Quantity/reel	Tape material
4.0±0.1	4.0±0.1	2.4±0.1	5.4±0.1	2.0±0.05	5.5±0.1	12.0±0.1	2.3±0.1	2,000pcs.	Plastic (Embossed)

**Reel Dimensions**

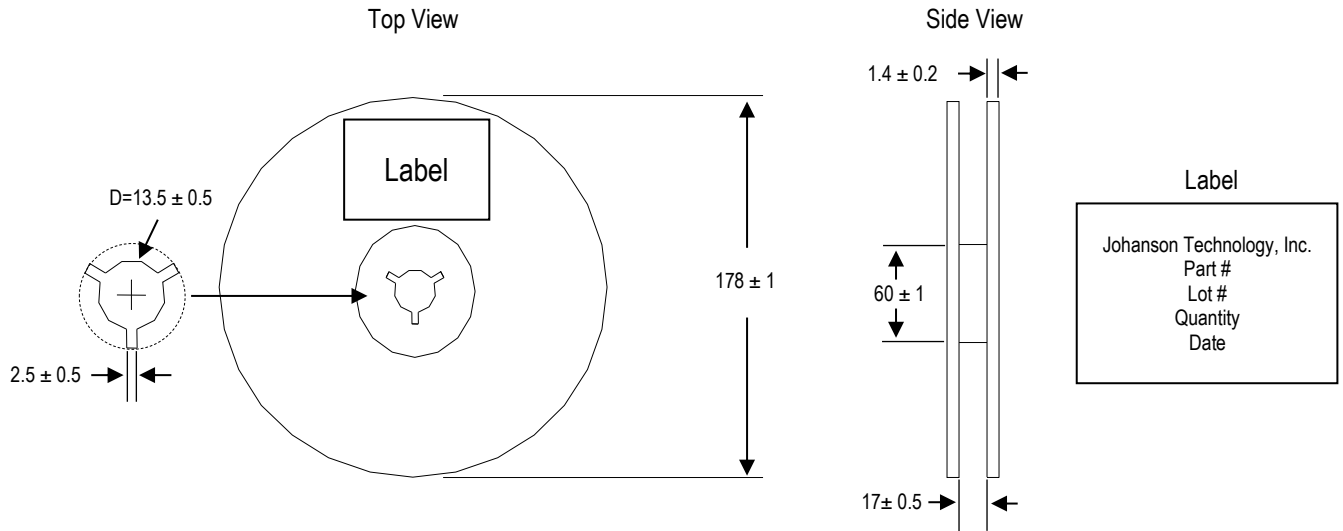

**Leader and Trailer Dimensions**

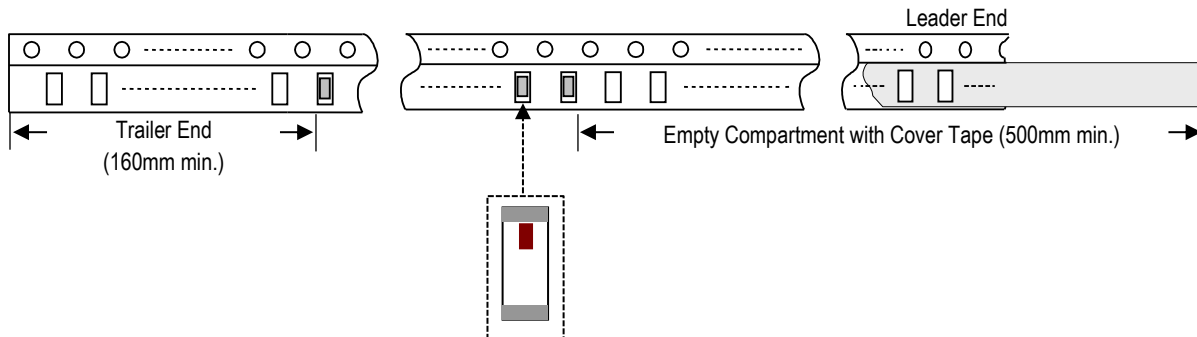

**Orderable Part Number**

Packaging Style	Part Number	Termination
Bulk (loose pcs.)	2450AT42B0100001B	Nickel Tin
T & R (7" Reel Embossed Tape)	2450AT42B0100001E (Qty: 2,000 pcs./reel)	
Evaluation Board with 1 SMA Connector	2450AT42B0100001CE1	

**Important Links**

[2450AT42B0100001E Product Page](#)

[More RF Chip Antennas](#)

[Antenna Tuning, Optimization, and Validation Services](#)

[Soldering Information](#)

[MSL Information](#)

[Packaging Information](#)

[Recommended Storage Condition and Max Shelf Life](#)

[RoHS Compliance](#)

*Contact our application engineers for a PCB layout review.*

**Johanson Technology, Inc. reserves the right to make design changes without notice.  
All sales are subject to Johanson Technology, Inc. terms and conditions.**