

2.44 GHz RF Chip Antenna, *Above Metal**

- 2.4 – 2.48 GHz operational frequency
- Bluetooth, WLAN
- SMD, 5.0x2.0x1.5mm (LxWxT)
- Center-edge mount, circular PCB
- RoHS compliant and AEC-Q200 Qualified available

Johanson Technology, Inc. (JTI) miniature RF ceramic chip antennas are made using Low Temperature Co-fired Ceramic (LTCC) technology which has the ability to embed low and high dielectric constants inside our antenna. This enables our components to have high detuning resilience and stability over extreme temperatures (~2ppm).

**This antenna will generally have a metal layer directly underneath for proper operation, exceptions may apply.*

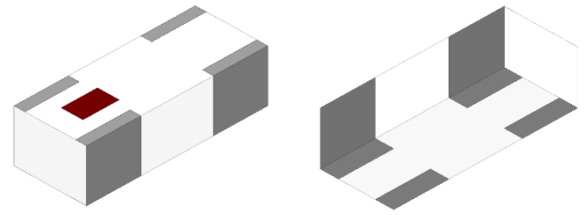

Recommended mounting locations for this antenna

PCB Center-edge



Circular

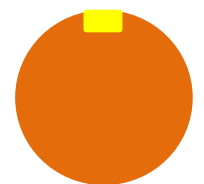

General Specifications^{1 2}

Operational Frequency (MHz)	2400 - 2480	
Impedance (Ω)	50	
	Mounting Configuration 1 (See pages 3-4)	Mounting Configuration 2 (See pages 5-6)
Return Loss (dB)	2.7 Min.	3.5 Min.
Peak Gain (dBi)	-1.0 Typ.	-1.0 Typ.
Average Gain (dBi)	-3.5 Typ.	-5.0 Typ.
Average Radiated Efficiency (%)	26	32

Maximum Ratings

Power Capacity (W)	2 Max. (CW)
Operating Temperature ($^{\circ}\text{C}$)	-40 to +85
Recommended Storage Conditions post-installation ($^{\circ}\text{C}$)	-40 to +85
Recommended Storage Conditions and Period for Unused T&R Product	45% - 75% RH +5 to +35 $^{\circ}\text{C}$ 18 Months Max.

¹ Typical value represents average measurement at 25 $^{\circ}\text{C}$. Min./Max. values represent measurements over specified operating temperature.

² General specifications measured on Johanson's evaluation board P/N 2450AT42E010B001CE1.

Mechanical Dimensions

	Inches			Millimeters		
L	0.197	±	0.008	5.00	±	0.2
W	0.079	±	0.008	2.00	±	0.2
T	0.059	±	0.008	1.50	±	0.2
a	0.020	±	0.008	0.50	±	0.2
b	0.059	±	0.008	1.50	±	0.2
c	0.012		Max.	0.30		Max.

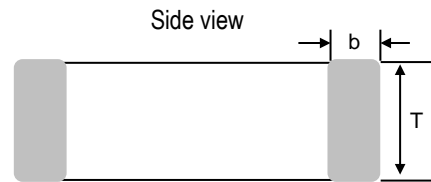
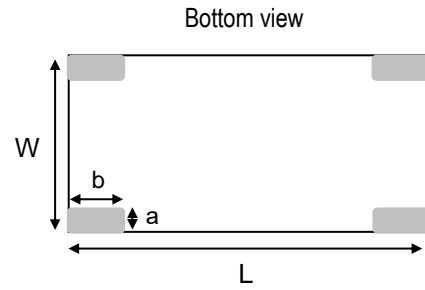

Terminal Configuration³

Pin Number	Function
1	Feed
2	NC*
3	GND
4	GND

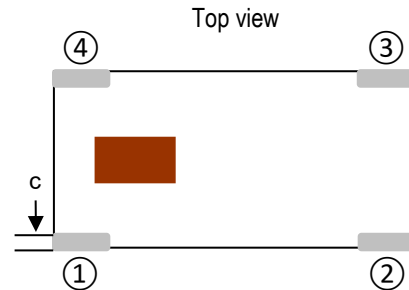

³ The termination type is Nickel Tin. Go to: <https://www.johansontechnology.com/ipcsoldering-profile> for Typical Soldering Profile.

* This terminal must be soldered for anchoring and mechanical stability.

Evaluation Board and Recommended Mounting Configuration 1 (P/N 2450AT42E010B001CE1)

All units in mm

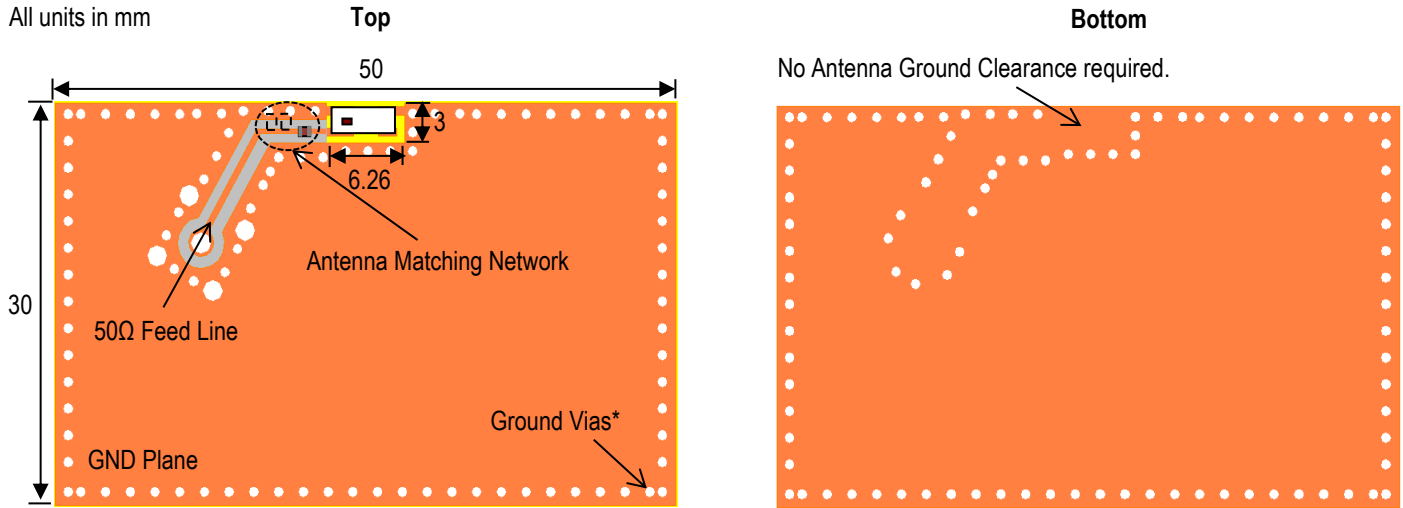

PCB Thickness: 1.57mm

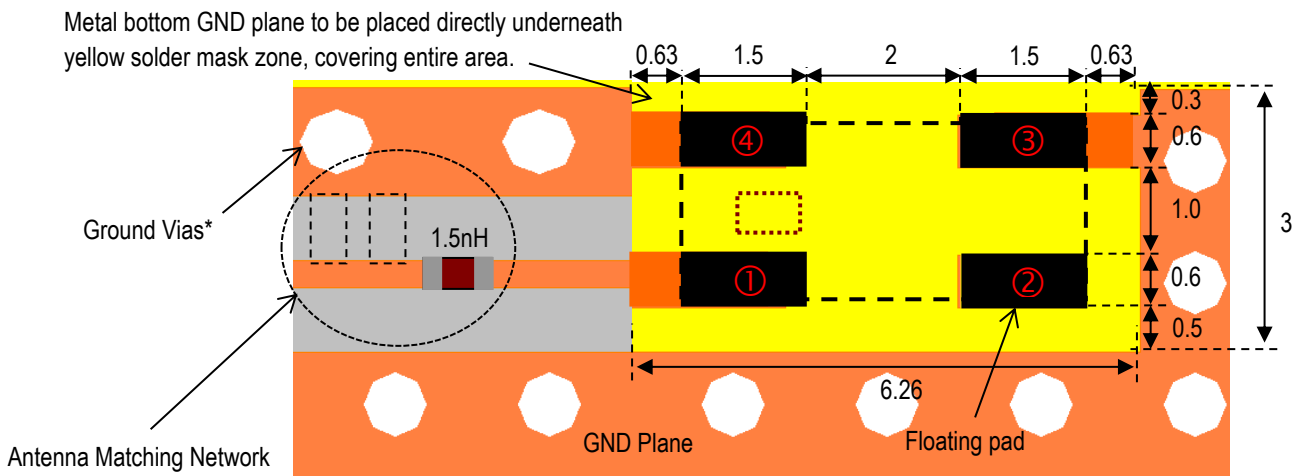

JTI P/N's for Matching Network⁴

Inductor (1.5nH): LRC0402CS1N5GV001T

*Note: Ground Vias are highly recommended to have better antenna efficiency.

If you'd like the CAD PCB layout or have any questions, contact our application engineers at <https://www.johansontechnology.com/ask-a-question>

⁴ It is recommended that the designer leave available slots for the topology of the network. The antenna matching network values above are used when antenna is mounted on Johanson's evaluation board. The matching values on client's PCB will be different, depending on the layout, thickness, material, etc. Go to: <https://www.johansontechnology.com/tuning> and see how to obtain the new values.

Evaluation Board Typical Return Loss Measurement (P/N 2450AT42E010B001CE1)

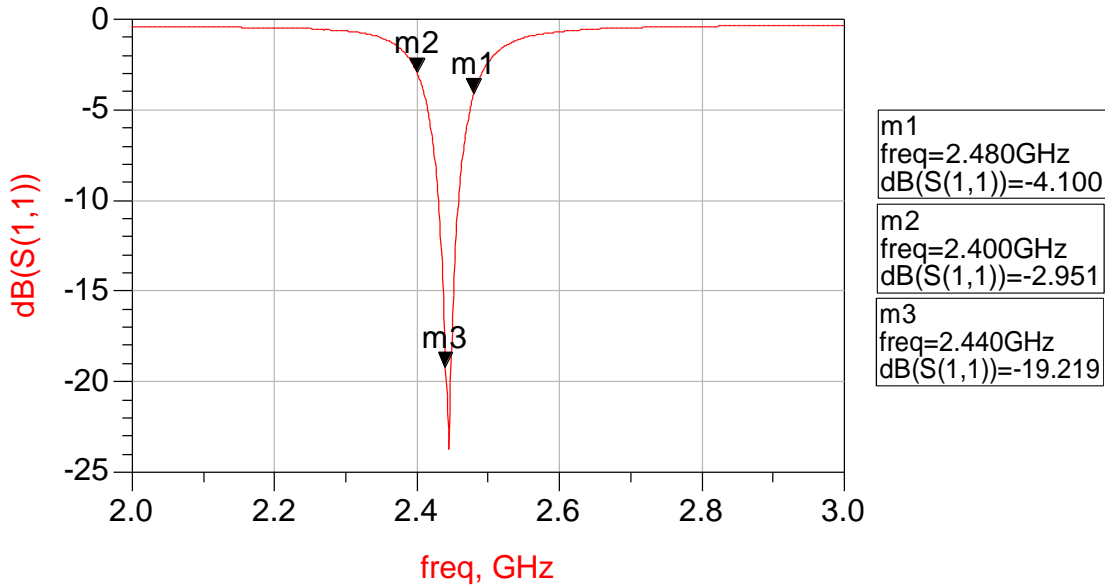

Evaluation Board Typical 2D Radiation Patterns @2440 MHz (P/N 2450AT42E010B001CE1)

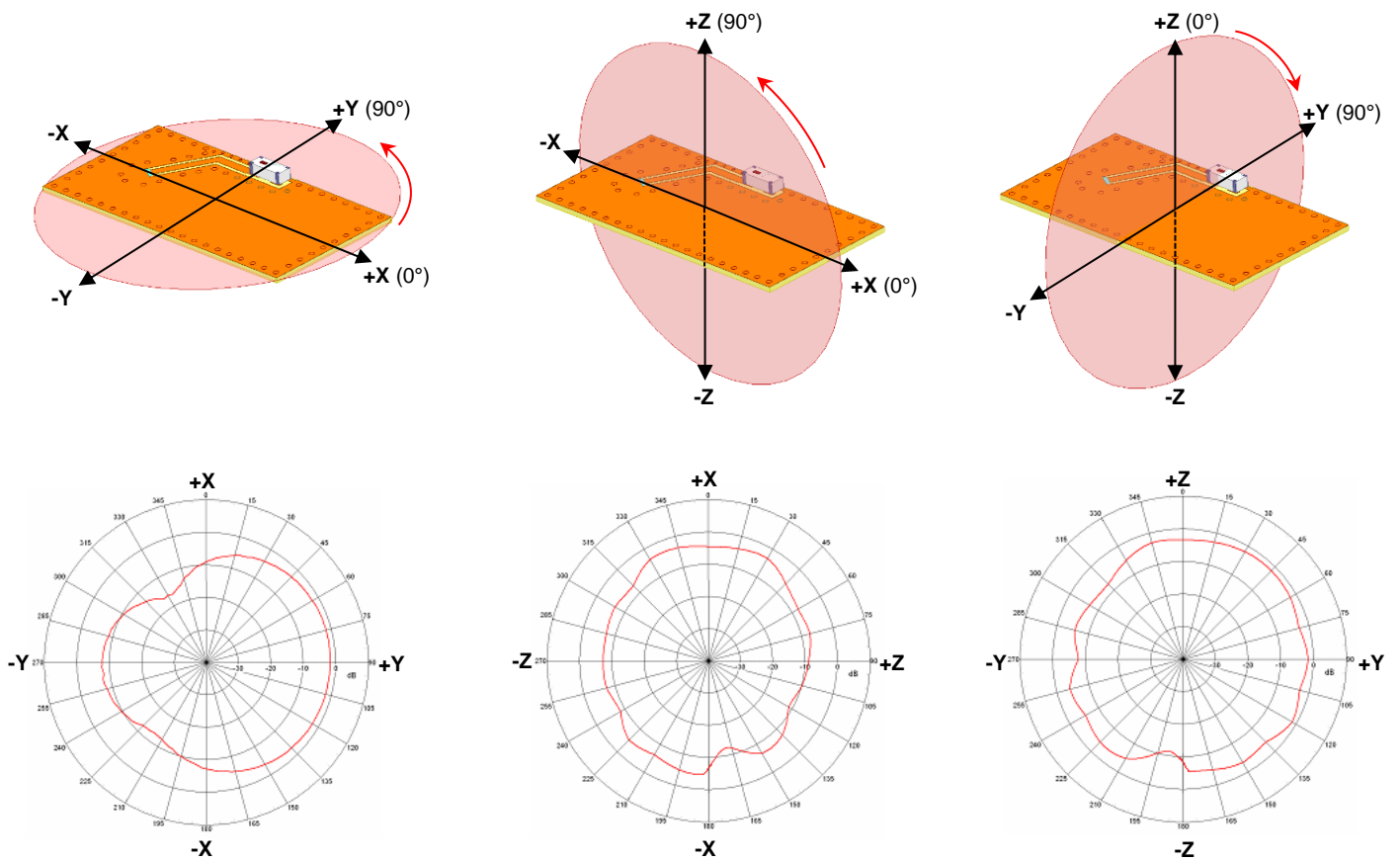

Evaluation Board and Recommended Mounting Configuration 2 (P/N 2450AT42E010B001CE2)

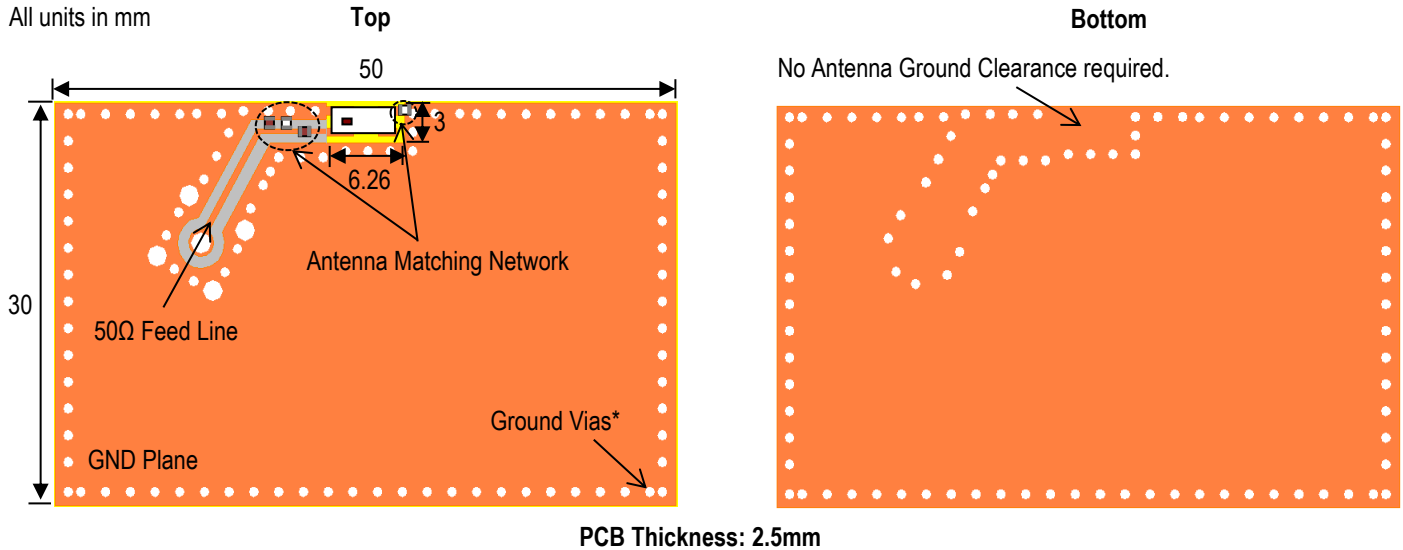

Metal bottom GND plane to be placed directly underneath yellow solder mask zone, covering entire area.

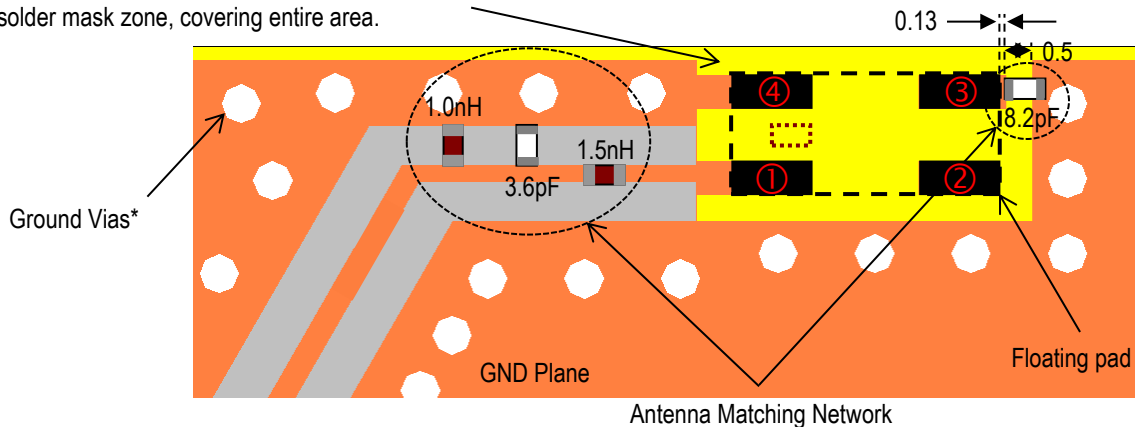

JTI P/N's for Matching Network⁵

Inductor (1.5nH): LRC0402CS1N5GV001T

Capacitor (3.6pF): QSCF500Q3R6B1GV001T

Inductor (1.0nH): LRC0402CS1N0GV001T

Capacitor (8.2pF): QSCF500Q8R2B1GV001T

*Note: Ground Vias are highly recommended to have better antenna efficiency.

If you'd like the CAD PCB layout or have any questions,
contact our application engineers at <https://www.johansontechnology.com/ask-a-question>

⁵ It is recommended that the designer leave available slots for the topology of the network. The antenna matching network values above are used when antenna is mounted on Johanson's evaluation board. The matching values on client's PCB will be different, depending on the layout, thickness, material, etc. Go to: <https://www.johansontechnology.com/tuning> and see how to obtain the new values.

Evaluation Board Typical Return Loss Measurement (P/N 2450AT42E010B001CE2)

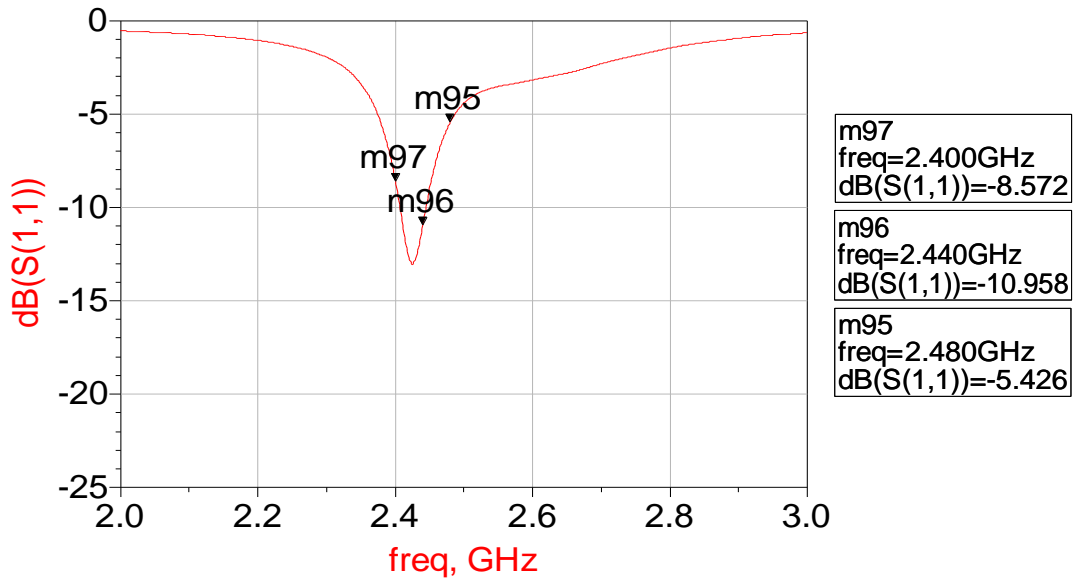

Evaluation Board Typical 2D Radiation Patterns @2440 MHz (P/N 2450AT42E010B001CE2)

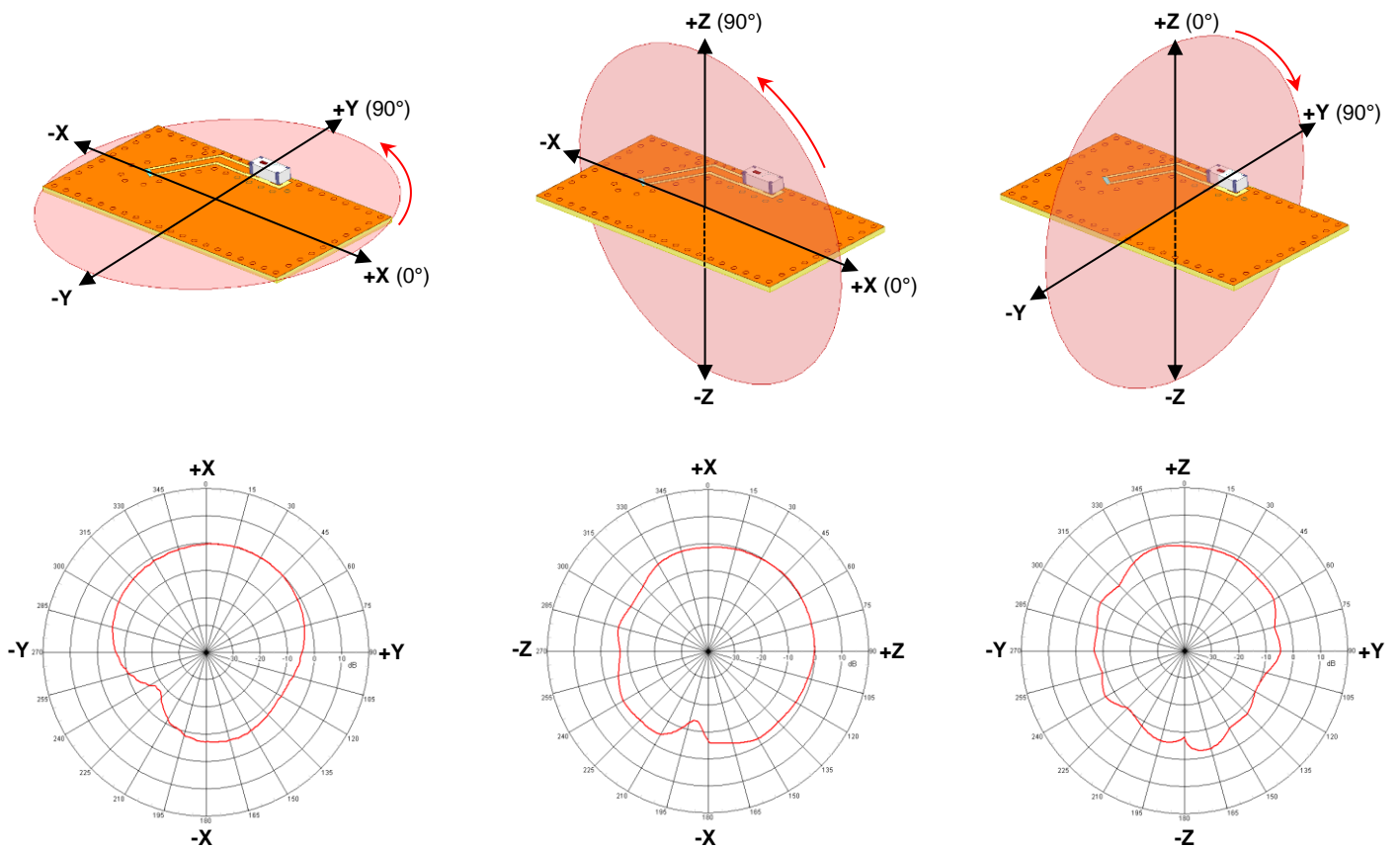

Wider Tuning (For reference only, no evaluation board available)

By re-tuning our Evaluation Board 1 (P/N 2450AT42E010B001CE1), return loss can be improved over the bandwidth as a whole. An additional tuning component is placed between antenna pin 3 and GND.

Metal bottom GND plane to be placed directly underneath yellow solder mask zone, covering entire area.

All units in mm

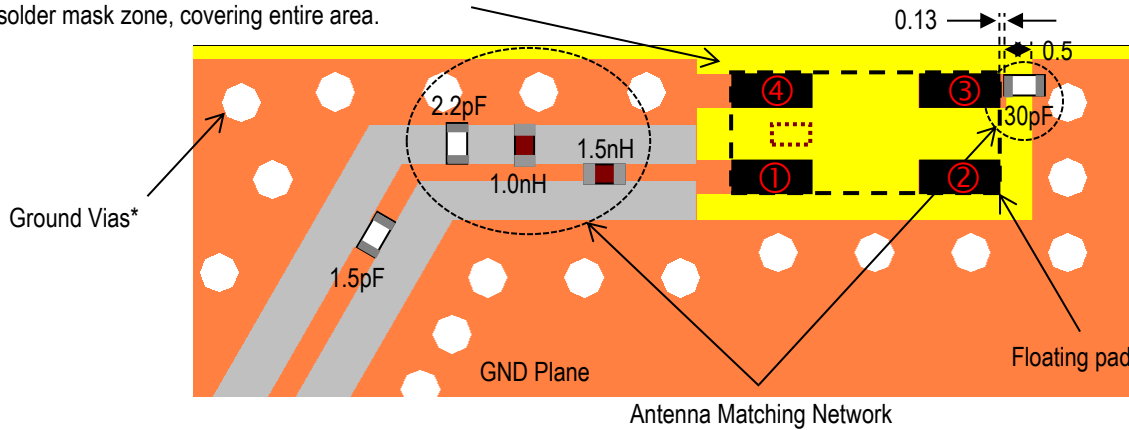

JTI P/N's for Matching Network⁶

Inductor (1.5nH): LRC0402CS1N5GV001T

Inductor (1.0nH): LRC0402CS1N0GV001T

Capacitor (2.2pF): QSCF500Q2R2B1GV001T

Capacitor (1.5pF): QSCF500Q1R5B1GV001T

Capacitor (30pF): QSCF500Q300J1GV001T

Return Loss

Average Radiated Efficiency: 24%

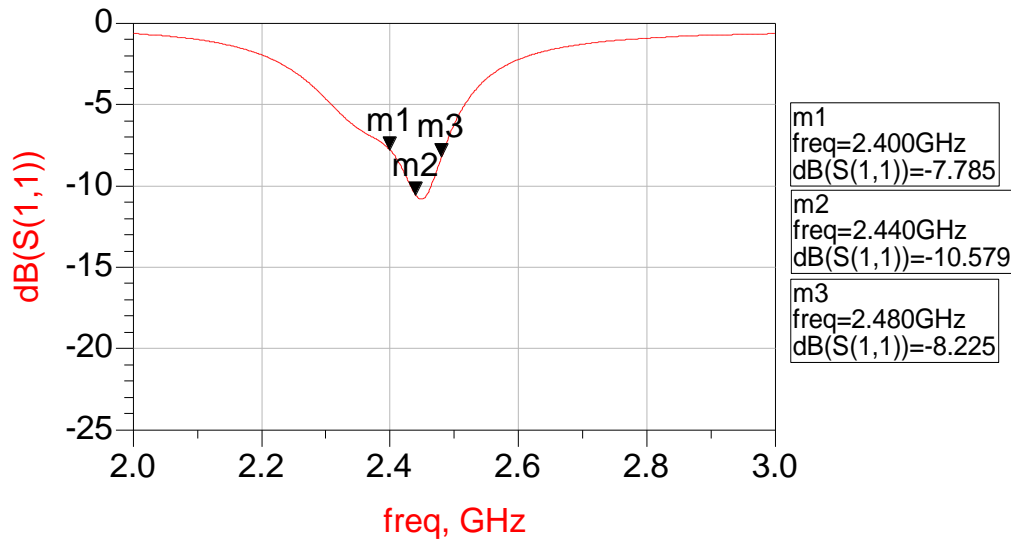

If you have any questions,
contact our application engineers at <https://www.johansontechnology.com/ask-a-question>

⁶ It is recommended that the designer leave available slots for the topology of the network. The antenna matching network values above are used when antenna is mounted on Johanson's evaluation board. The matching values on client's PCB will be different, depending on the layout, thickness, material, etc. Go to: <https://www.johansontechnology.com/tuning> and see how to obtain the new values.

Recommended Mounting Consideration for Circular PCBs (no evaluation board available)

All units in mm

Top

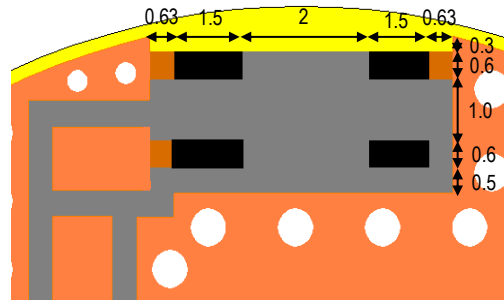
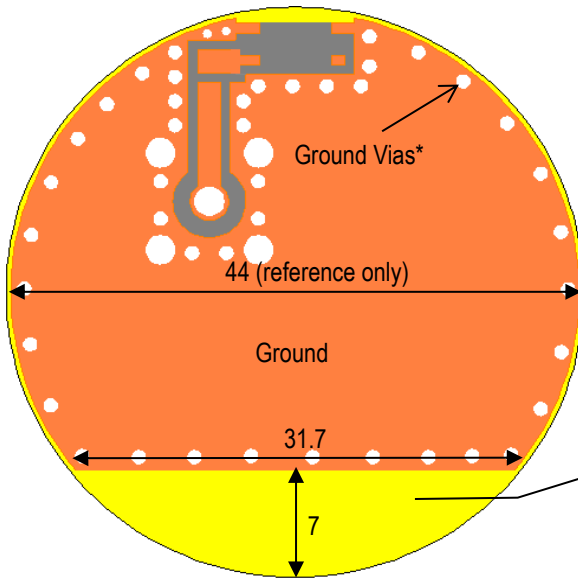

Receding the GND plane helps shape the radiation pattern in a more isometric (spherical) shape. We recommend this layout if space allows.

Bottom

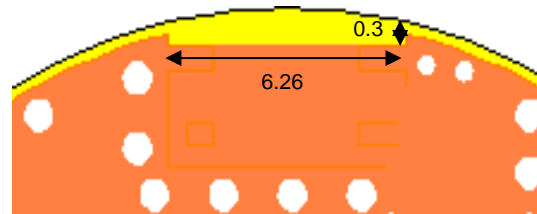
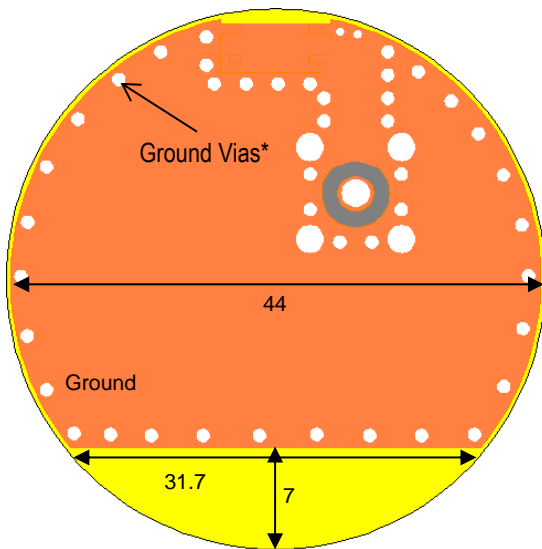

*Note1: Ground Vias are highly recommended to have better antenna efficiency.

If you have any questions regarding the implementation of this antenna in your PCB's layout, please contact our application engineers at <https://www.johansontechnology.com/ask-a-question>



Antenna Variant Based on Substrate Thickness

Since the antenna's efficiency is largely affected by the thickness of the PCB's substrate, we offer another variant of this antenna. This allows a more robust design to fit your PCB. The disparity between antenna variations is internal only; variations are identical in dimension and footprint compatible.

Refer to the diagram below to understand what is meant by substrate thickness.

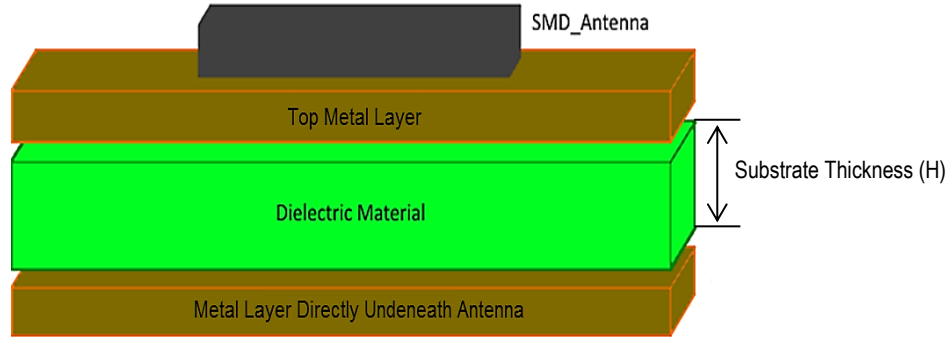

PCB Substrate Thickness	Recommended JTI P/N
≤1.0mm	2450AT42E0100001E
1.1mm - 2.5mm	2450AT42E010B001E

Antenna Variant Typical Efficiency Values @2.44GHz on 30x50 mm PCB

The below table represents simulated values and are for reference only.

PCB Substrate Thickness	Antenna Efficiency @2.44 GHz	
	2450AT42E0100001E	2450AT42E010B001E
H = 0.12 mm	1.95%	1.02%
H = 0.7 mm	29.20%	9.30%
H = 1.5 mm	23.30%	38.00%
H = 2.5 mm	21.60%	42.00%

Recommended Antenna Orientation

2450AT42E010B001E is not symmetrical internally and therefore it is not recommended to mirror the layout. We recommend designers to mount the antenna in the orientation of our recommended layout.

Recommended Layout

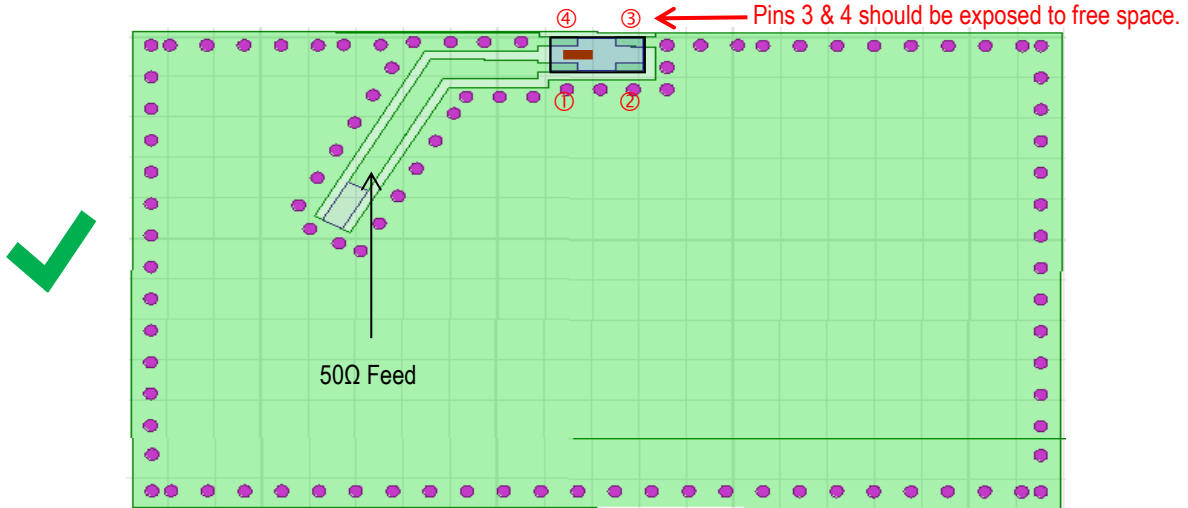

Right-feed Layout

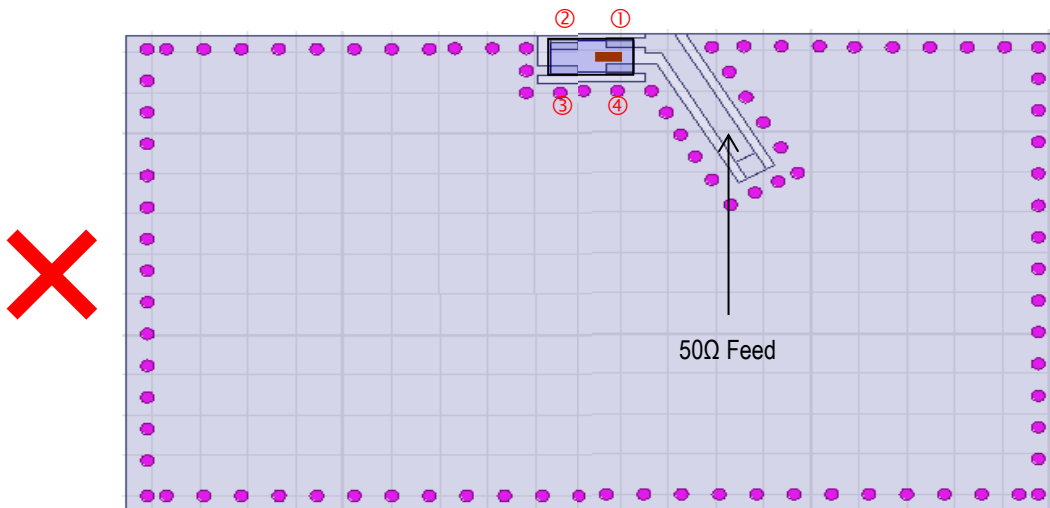

Tape and Reel Specification (Units in mm)

Tape Dimensions

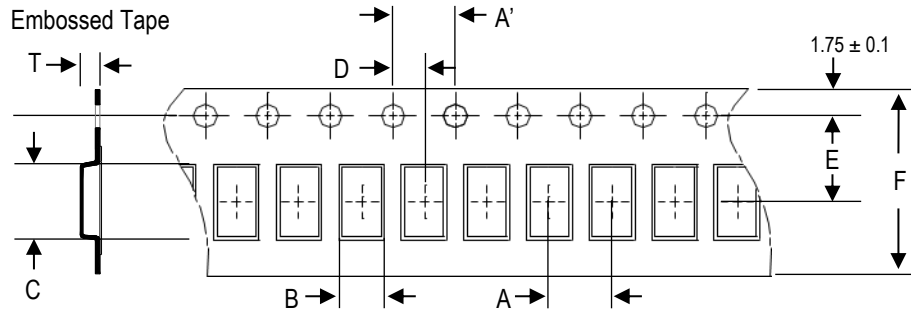

A	A'	B	C	D	E	F	T	Quantity/reel	Tape material
4.0±0.1	4.0±0.05	2.4±0.1	5.4±0.1	2.0±0.05	5.5±0.05	12.0±0.1	1.8±0.1	2,000pcs.	Plastic (Embossed)

Reel Dimensions

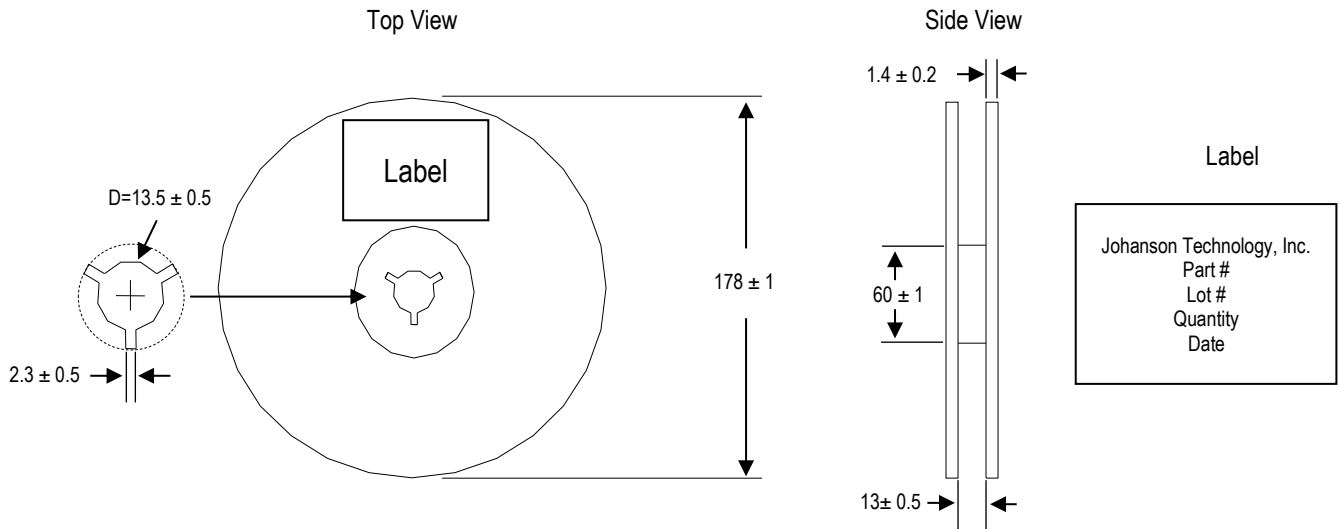

Leader and Trailer Dimensions

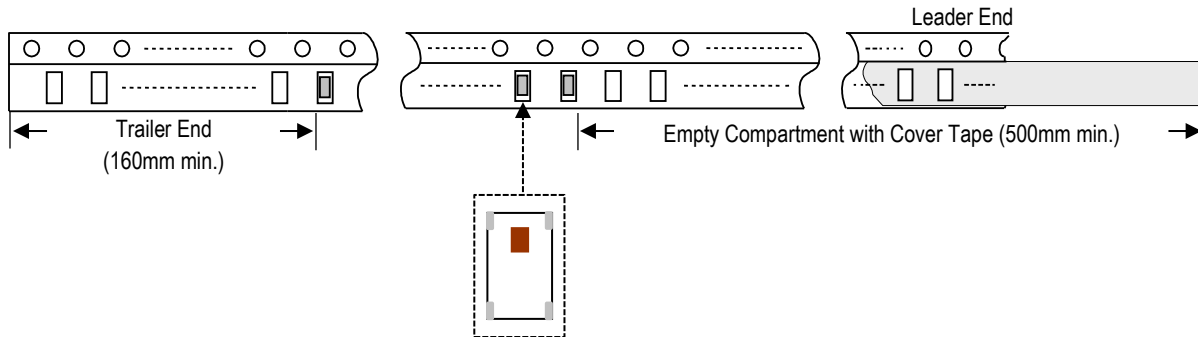

Orderable Part Number

Packaging Style	Part Number	Termination
Bulk (loose pcs.)	2450AT42E010B001B	Nickel Tin
T & R (7" Reel Embossed Tape)	2450AT42E010B001E (Qty: 2,000 pcs./reel)	
Evaluation Board with 1 SMA Connector (1.5mm PCB)	2450AT42E010B001CE1 (Page 3)	
Evaluation Board with 1 SMA Connector (2.5mm PCB)	2450AT42E010B001CE2 (Page 5)	

Important Links

[2450AT42E010B001E Product Page](#)

[More RF Chip Antennas](#)

[Antenna Tuning, Optimization, and Validation Services](#)

[Soldering Information](#)

[MSL Information](#)

[Packaging Information](#)

[Recommended Storage Condition and Max Shelf Life](#)

[RoHS Compliance](#)

Contact our application engineers for a PCB layout review.

**Johanson Technology, Inc. reserves the right to make design changes without notice.
All sales are subject to Johanson Technology, Inc. terms and conditions.**