

1.85 GHz Low Pass Filter

- 1805 - 1910 MHz passband
- Very low insertion loss
- High out-of-band selectivity
- SMD, EIA 0806 (2.0x1.5x0.98mm)
- RoHS complaint

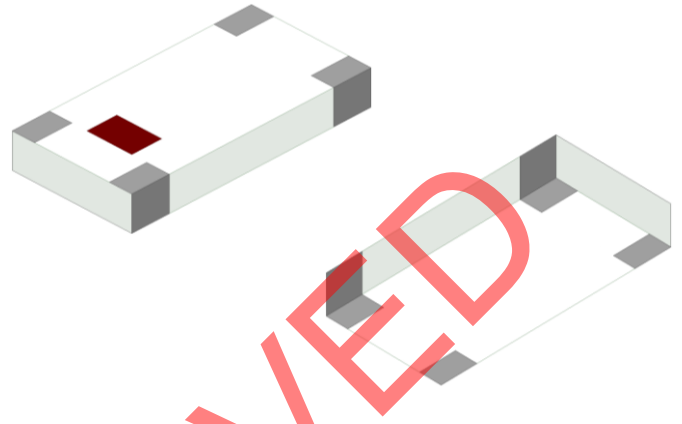

General Specifications^{1 2}

Impedance (Ω)	1805 - 1910 MHz	50	
Insertion Loss (dB)	1805 - 1910 MHz		0.4 Max.
Return Loss (dB)	1805 - 1910 MHz	11.7 Min.	
Attenuation (dB)	3610 - 3820 MHz	30 Min.	
	5415 - 5730 MHz	20 Min.	

Maximum Ratings

Power Capacity (W)	3 Max. (CW)
Operating Temperature ($^{\circ}\text{C}$)	-40 to +105
Recommended Storage Conditions post-installation ($^{\circ}\text{C}$)	-40 to +105
Recommended Storage Conditions and Period for Unused T&R Product	45% - 60% RH +5 to +35 18 Months Max.

¹ Typical value represents average measurement at 25 $^{\circ}\text{C}$. Min./Max. values represent measurements over specified operating temperature.

² General specifications measured on Johanson's evaluation board P/N 1850LP16A0105001CE1.

Mechanical Dimensions

	Inches			Millimeters		
L	0.080	±	0.004	2.03	±	0.10
W	0.061	±	0.004	1.55	±	0.10
T	0.039	±	0.006	0.98	±	0.15
a	0.022	±	0.010	0.56	±	0.25
b	0.014	±	0.006	0.35	±	0.15

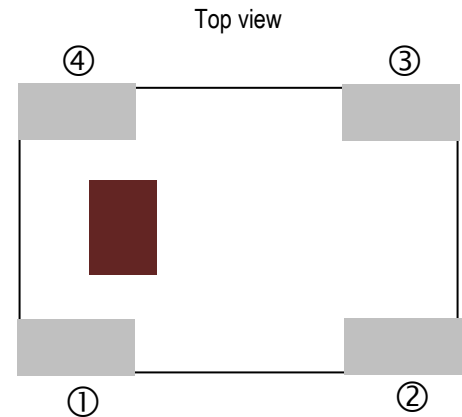
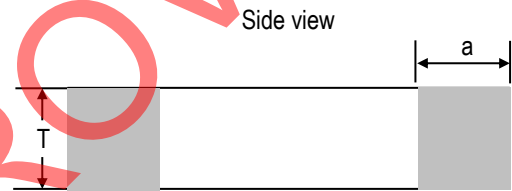
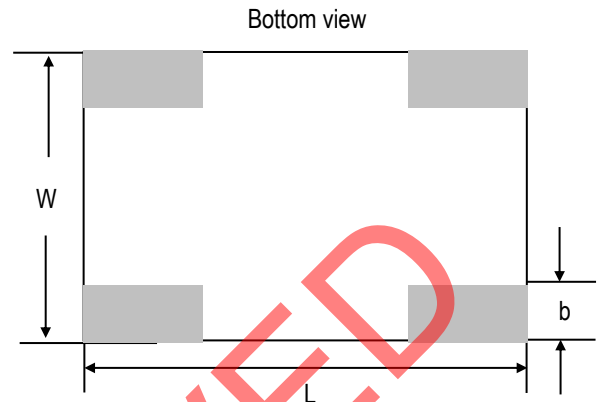

Terminal Configuration³

Pin Number	Function
1	INPUT/OUTPUT
2	INPUT/OUTPUT
3	GND
4	GND

³ The termination type is Nickel Tin. Go to: <https://www.johansontechnology.com/ipcsoldering-profile> for Typical Soldering Profile.

Recommended PCB Layout

Note: Mount device with colored mark facing up.

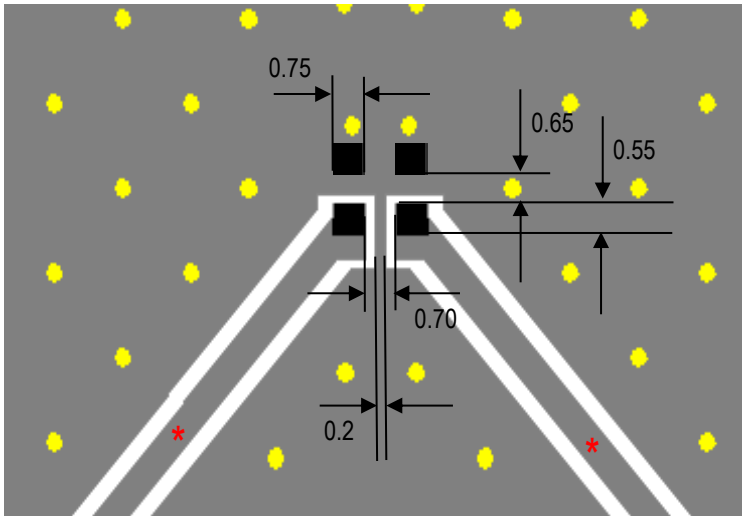

Units in mm

 Solder Resist

 Land

 Through-hole ($\phi 0.30$)

* Transmission line width should be designed to match 50 Ω characteristic impedance, depending on PCB material and thickness.

If you'd like the CAD PCB layout or have any questions, contact our application engineers at <https://www.johansontechnology.com/ask-a-question>

Measuring Diagram

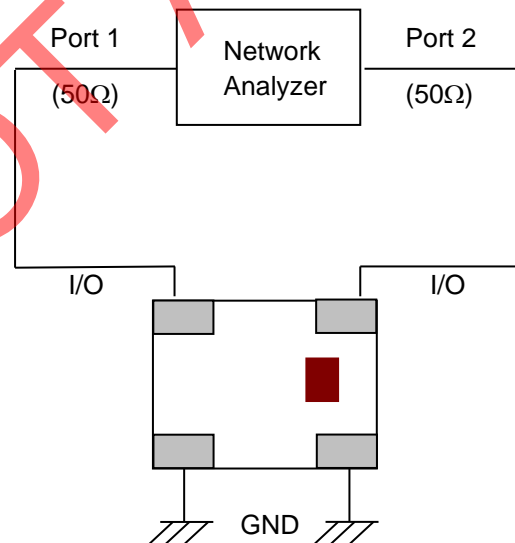



RF Measurement (T = 25°C)

Insertion Loss, Return Loss, Attenuation

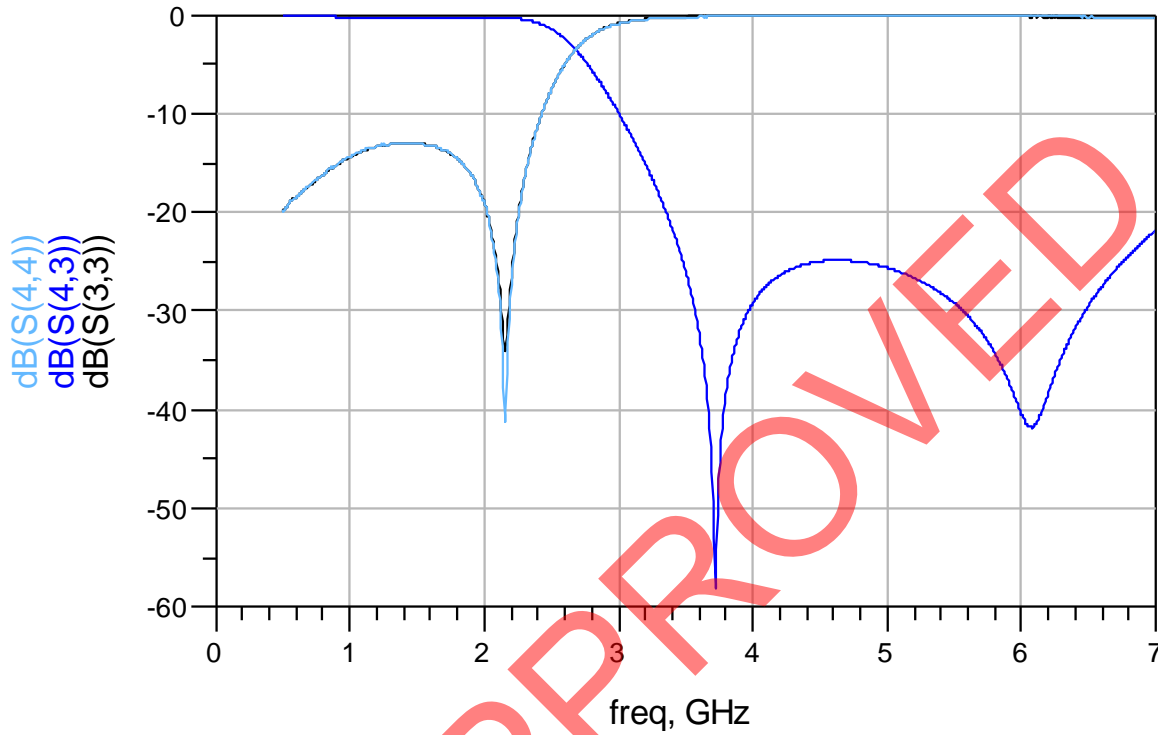

S-parameter and layout file available upon request. Please contact us at: <https://www.johansontechnology.com/ask-a-question>

NOT APPROVED

Tape and Reel Specification (Units in mm)

Tape Dimensions

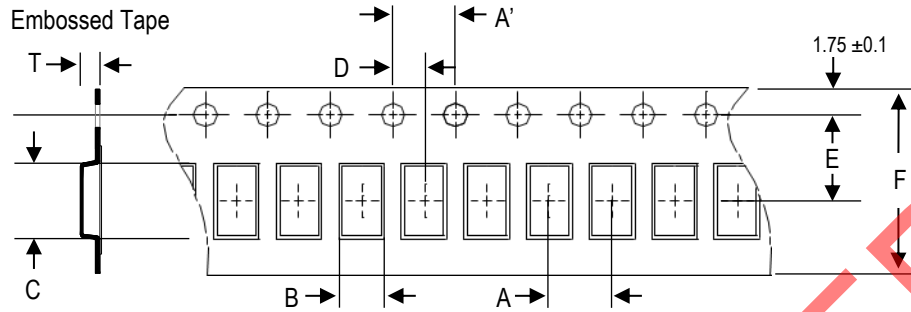

A	A'	B	C	D	E	F	T	Quantity/reel	Tape material
4.0 ± 0.1	4.0 ± 0.1	1.85 ± 0.1	2.40 ± 0.1	2.0 ± 0.1	3.5 ± 0.1	8.0 ± 0.1	1.05 ± 0.05	4,000pcs.	Plastic (Embossed)

Reel Dimensions

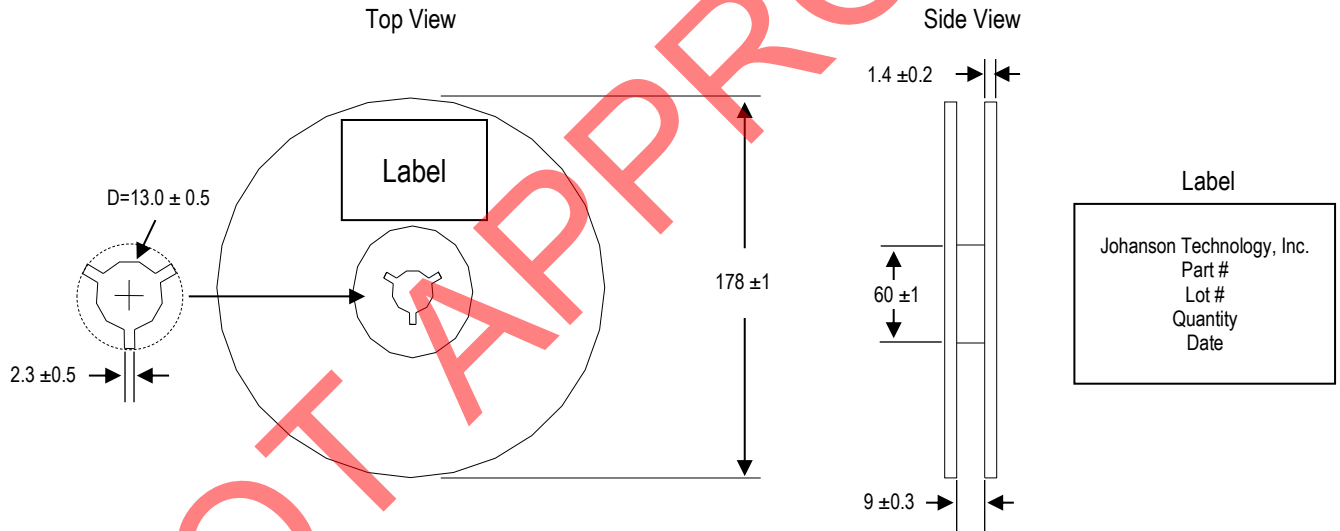

Leader and Trailer Dimensions

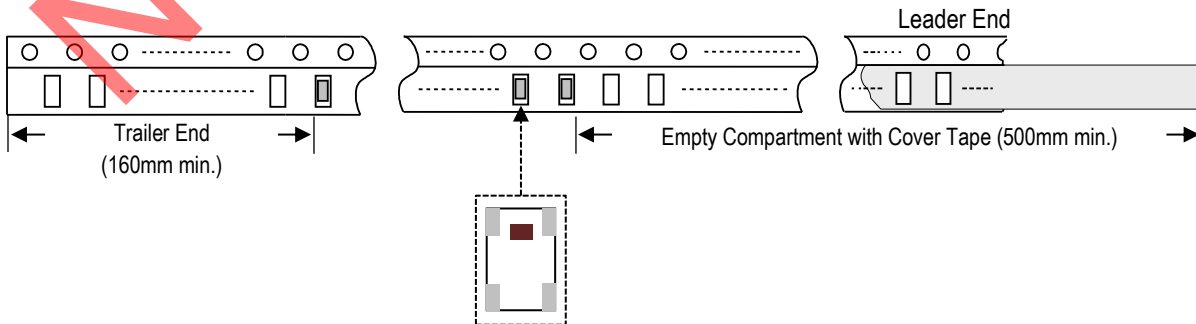

Orderable Part Number

Packaging Style	Part Number	Termination
Bulk (loose pcs.)	1850LP16A0105001B	Nickel Tin
T & R (7" Reel Embossed Tape)	1850LP16A0105001E (Qty: 4,000 pcs/reel)	
Evaluation Board with 2 SMA Connectors	1850LP16A0105001CE1	

Important Links

[1850LP16A0105001E Product Page](#)

[More Band Pass Filters](#)

[Antenna Tuning, Optimization, and Validation Services](#)

[Soldering Information](#)

[MSL Information](#)

[Packaging Information](#)

[Recommended Storage Condition and Max Shelf Life](#)

[RoHS Compliance](#)

NOT APPROVED

**Johanson Technology, Inc. reserves the right to make design changes without notice.
All sales are subject to Johanson Technology, Inc. terms and conditions.**