

5.5 GHz RF Balun

- 3 – 8 GHz pass band
- 1:2 Impedance
- SMD, EIA 0805
- RoHS compliant
- For wireless communication applications

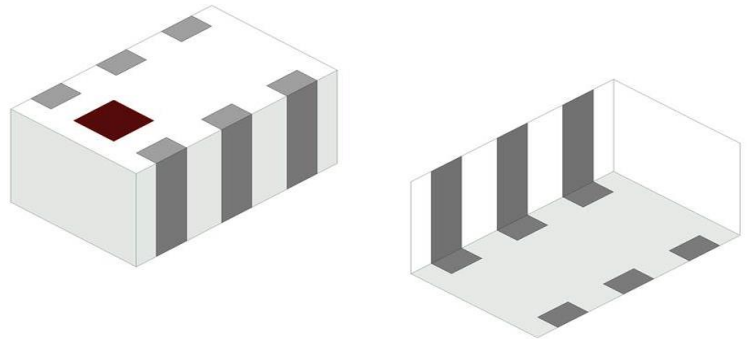

General Specifications^{1 2}

Passband Frequency (MHz)	3000 – 8000
Unbalanced Impedance (Ω)	50
Balanced Impedance (Ω)	100
Insertion Loss (dB)	1.8 Max.
Return Loss (dB)	9.5 Min.
Phase Difference (degree)	180 \pm 20
Amplitude Difference (dB)	2 Max.

Maximum Ratings

Power Capacity (W)	0.5 Max. (CW)
Operating Temperature ($^{\circ}$ C)	-40 to +85
Recommended Storage Conditions post-installation ($^{\circ}$ C)	-40 to +85
Recommended Storage Conditions and Period for Unused T&R Product	45% - 75% RH +5 to +35 $^{\circ}$ C 18 Months Max.

¹ Typical value represents average measurement at 25 $^{\circ}$ C. Min./Max. values represent measurements over specified operating temperature.

² General specifications measured on Johanson's evaluation board P/N 5500BL15U0100001CE1.

Mechanical Dimensions

	Inches			Millimeters		
L	0.079	±	0.004	2.00	±	0.10
W	0.049	±	0.004	1.25	±	0.10
T	0.037	±	0.004	0.95	±	0.10
a	0.012	±	0.004	0.30	±	0.10
b	0.008	±	0.004	0.20	±	0.10
c	0.012	+0.004/-0.008		0.30	+0.1/-0.2	
g	0.014	±	0.004	0.35	±	0.10
p	0.026	±	0.002	0.65	±	0.05

Bottom view

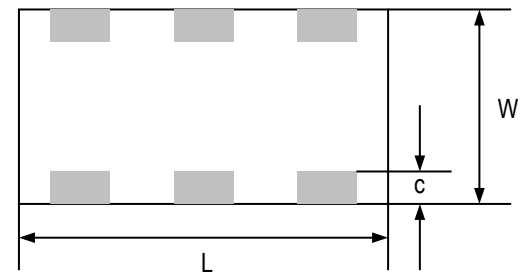

Side view

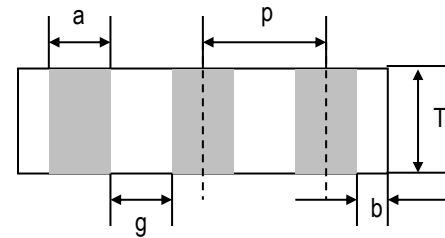

Terminal Configuration³

Pin Number	Function
1	Unbalanced Port (IN)
2	GND
3	NC or DC Feed
4	Balanced Port (OUT1)
5	GND
6	Balanced Port (OUT2)

Top view

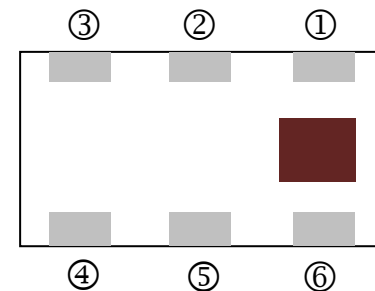



³ The termination type is Nickel Tin. Go to: <https://www.johansontechnology.com/ipcsoldering-profile> for Typical Soldering Profile.

Recommended PCB Layout

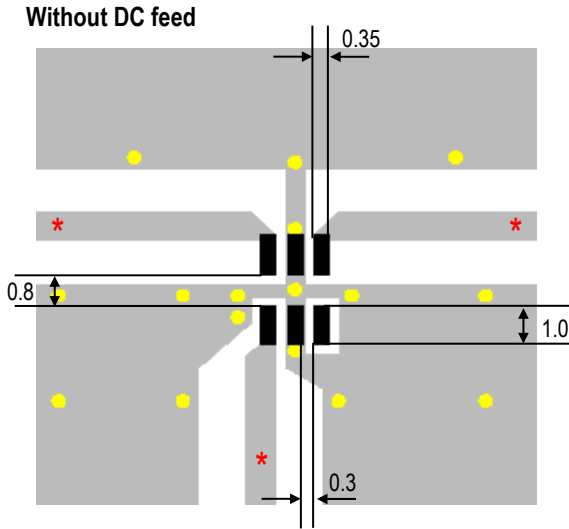
Note: Mount device with colored mark facing up.



Units: mm

-  Solder Resist
-  Land
-  Through-hole (Φ 0.3)

* Transmission line width should be designed to match 50 Ω characteristic impedance, depending on PCB material and thickness.

Additional note: A series choke inductor (~8.2nH) should be connected at Pin3 for DC-Feed function.

If you would like the full reference design package or have any questions, contact our application engineers at <https://www.johansontechnology.com/ask-a-question>

Internal Equivalent Circuit

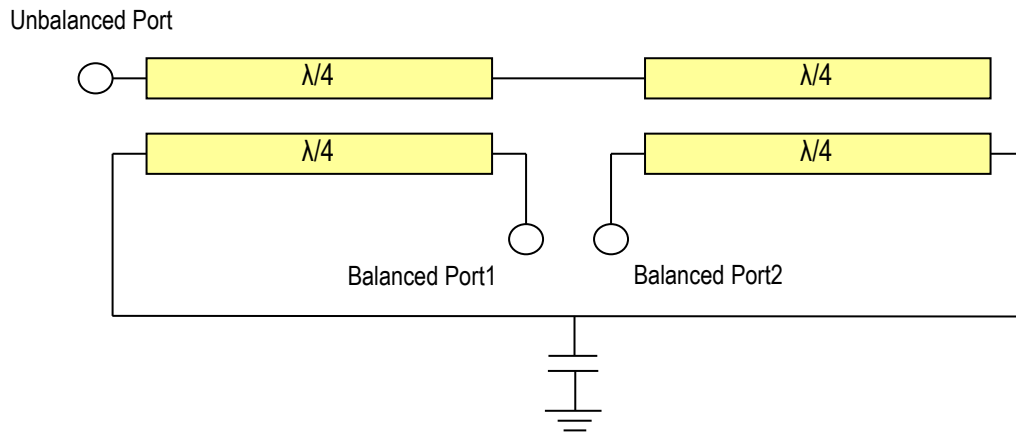

Measuring Diagram

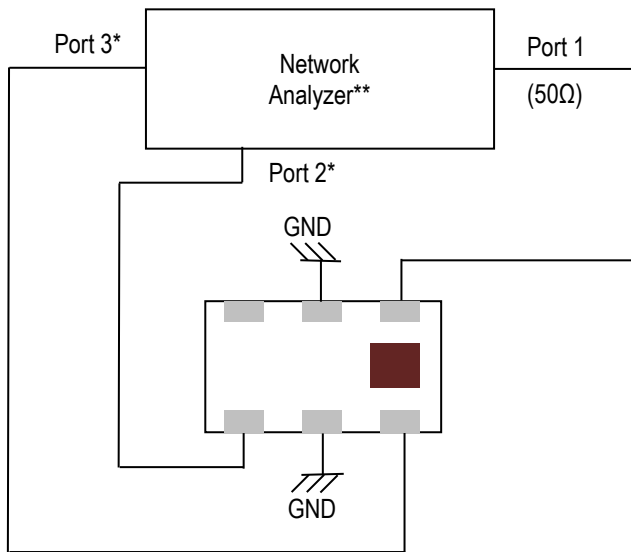

Port 1: Unbalanced Port

Ports 2 and 3: Balanced Port

Insertion Loss = S_{ds21}

Return Loss = S_{ss11}

Amplitude Balance = $\text{dB}(S(2,1)/S(3,1))$

Phase Balance = $\text{Phase}(S(2,1)/S(3,1))$

*Impedance for Ports 2 and 3 = Balanced Impedance/2

**E5071B from Agilent

RF Measurement (T=25°C)

Insertion Loss and Return Loss

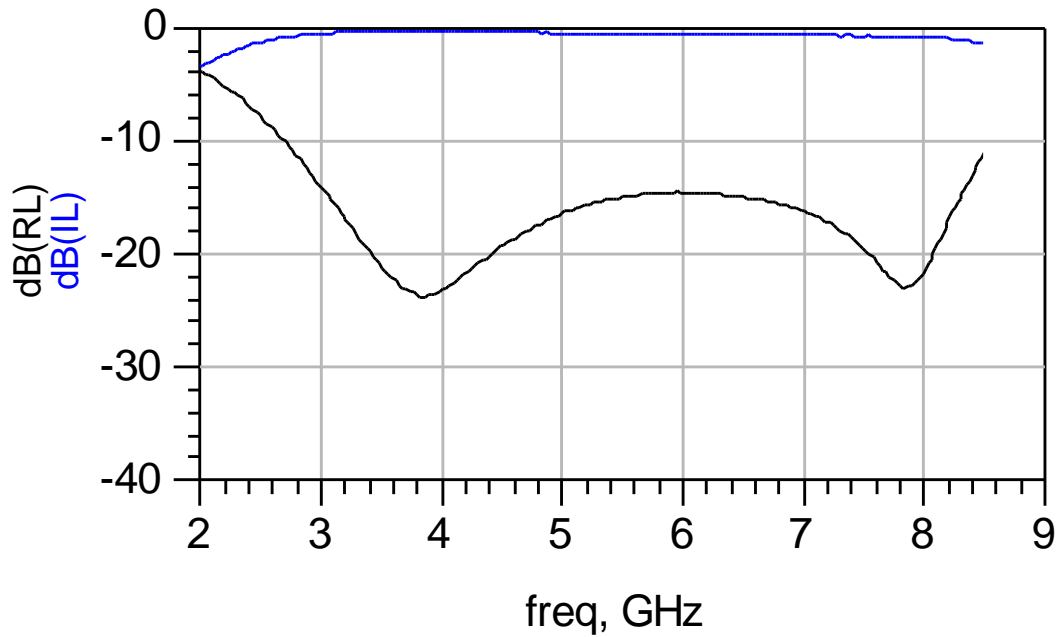

Phase Difference and Amplitude Difference

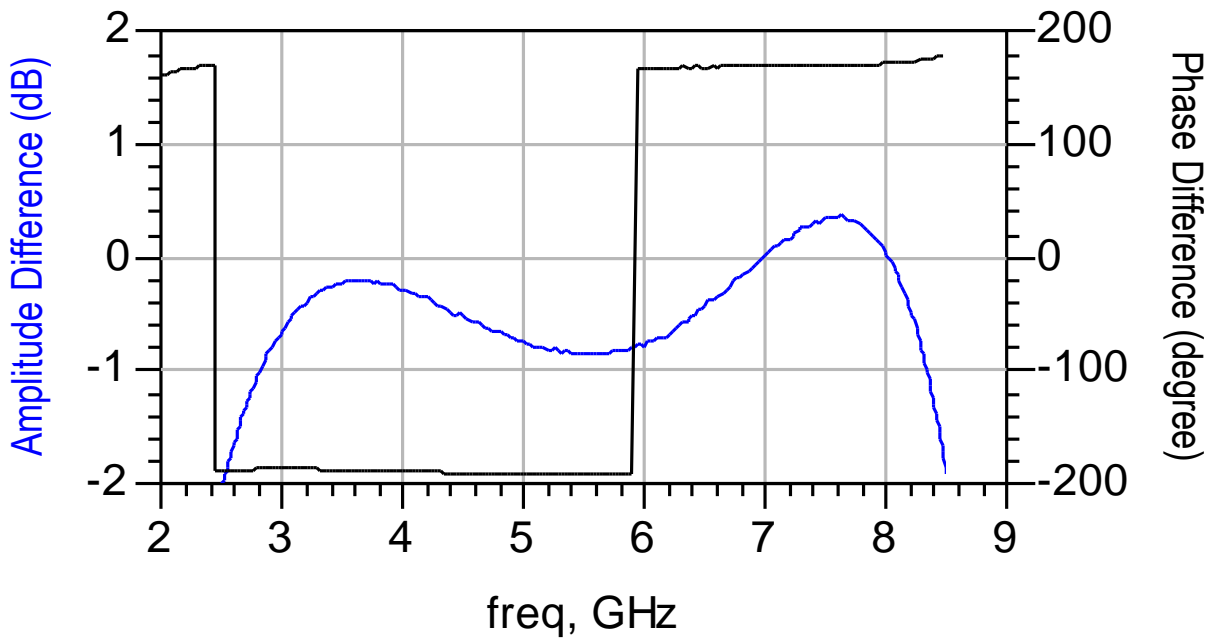

S-parameter and layout files available upon request. Please contact us at <https://www.johansontechnology.com/ask-a-question>

Tape and Reel Specification (Units in mm)

Tape Dimensions

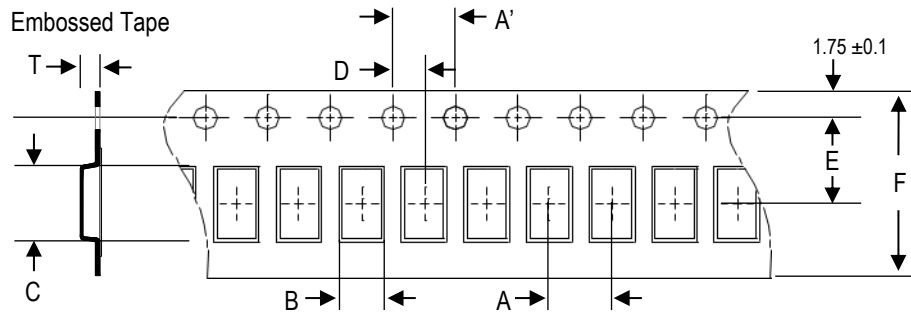

A	A'	B	C	D	E	F	T	Quantity/reel	Tape material
4.0 ±0.1	4.0 ±0.1	1.35 ±0.05	2.15 ±0.05	2.0 ±0.05	3.5 ±0.1	8.0 ±0.1	1.08 ±0.05	4,000pcs.	Plastic (Embossed)

Reel Dimensions

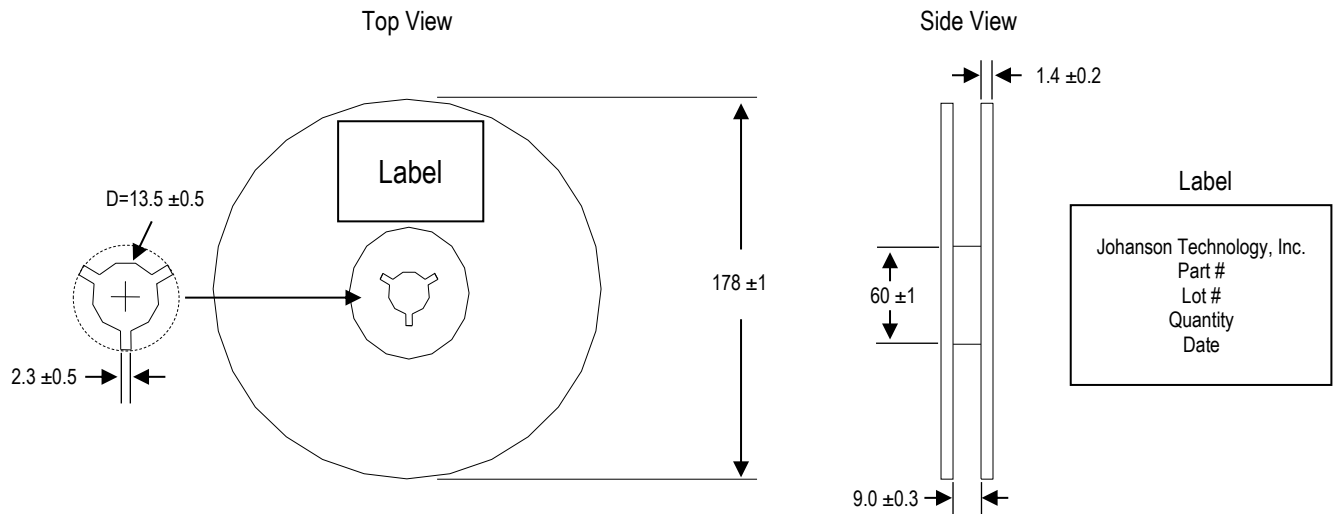

Leader and Trailer Dimensions

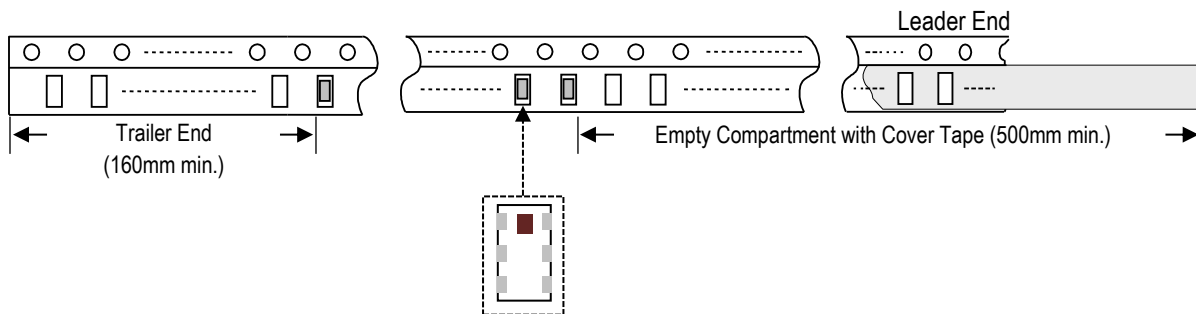

Orderable Part Number

Packaging Style	Part Number	Termination
Bulk (loose pcs.)	5500BL15U0100001B	Nickel Tin
T & R (7" Reel Embossed Tape)	5500BL15U0100001E (Qty: 4,000 pcs./reel)	
Evaluation Board with 3 SMA Connectors	5500BL15U0100001CE1	

Important Links

[5500BL15U0100001E Product Page](#)

[More RF Baluns](#)

[Antenna Tuning, Optimization, and Validation Services](#)

[Soldering Information](#)

[MSL Information](#)

[Packaging Information](#)

[Recommended Storage Condition and Max Shelf Life](#)

[RoHS Compliance](#)

Contact our application engineers for a PCB layout review.

Johanson Technology, Inc. reserves the right to make design changes without notice.

All sales are subject to Johanson Technology, Inc. terms and conditions.