

433 MHz ISM Chip Antenna, SMD (25x5x1.2mm), AEC-Q200 Qualified

Johanson Technology, Inc. (JTI) miniature RF ceramic chip antennas are made using Low Temperature Co-Fired Ceramic (LTCC) technology which has the ability to embed low and high dielectric constants inside our antenna. This enables our components to have high detuning resilience and stability over extreme temperatures (~2ppm).

Recommended mounting locations for this antenna

PCB End

PCB Corner

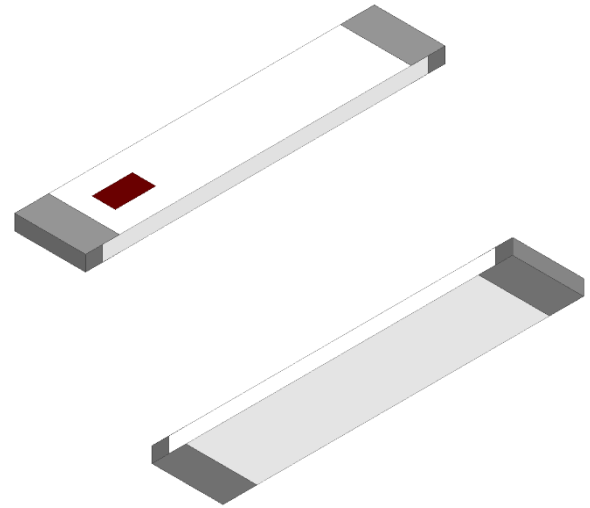

General Specifications^{1 2}

Passband Frequency (MHz) ^{3 4}	423 - 443	
Impedance (Ω)	50	
	Mounting Configuration 1 (See pages 3-4)	Mounting Configuration 2 (See pages 5-6)
Return Loss (dB)	9.5 Min.	5 Min.
Peak Gain (dBi)	-4.0 Typ.	-6.8 Typ.
Average Gain (dBi)	-4.0 Typ.	-7.2 Typ.

Maximum Ratings

Power Capacity (W)	2 Max. (CW)
Operating Temperature (°C)	-40 to +105
Recommended Storage Conditions post-installation (°C)	-40 to +105
Recommended Storage Conditions and Period for Unused T&R Product	45% - 75% RH +5 to +35 °C 18 Months Max.

¹ Typical value represents average measurement at 25°C. Min./Max. values represent measurements over specified operating temperature.

² General specifications measured on Johanson's evaluation board P/N 0433AT62A0020001CE1 and 0433AT62A0020001CE4.

³ See page 8 for tuned antenna performance at 403MHz.

⁴ See page 9 for tuned antenna performance at 460MHz.

Mechanical Dimensions

	Inches			Millimeters		
L	0.984	±	0.008	25.00	±	0.20
W	0.197	±	0.008	5.00	±	0.20
T	0.047	±	0.004	1.20	±	0.10
a1	0.020	±	0.008	0.50	±	0.20
a2	0.039	±	0.008	1.00	±	0.20

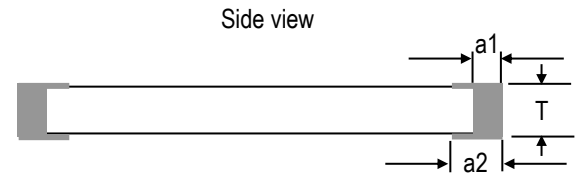
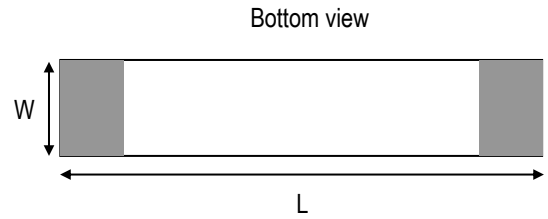

Terminal Configuration⁵

Pin Number	Function
1	Feed
2	NC*

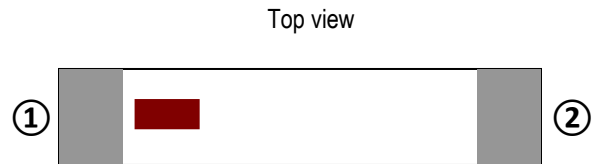

⁵ The termination type is Nickel Tin. Go to: <https://www.johansontechnology.com/ipcsoldering-profile> for Typical Soldering Profile.

* This terminal must be soldered for anchoring and mechanical stability.

Evaluation Board and Recommended Mounting Configuration 1 (P/N 0433AT62A0020001CE1)

All units in mm

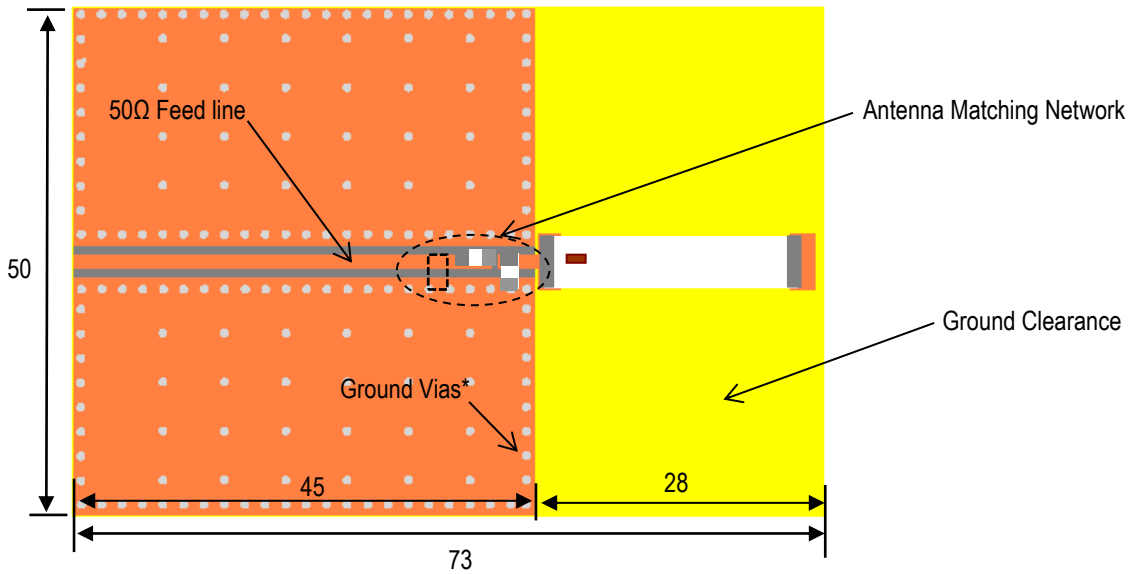

*Note: Ground Vias are highly recommended to have better antenna efficiency.

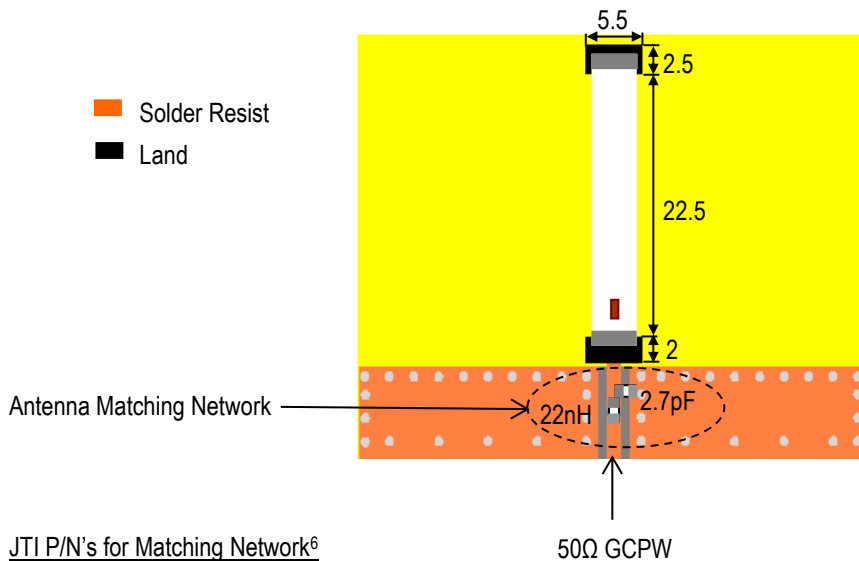

JTI P/N's for Matching Network⁶
 Cap (2.7pF): QSCF500Q2R7B1GV001T
 Inductor (22nH): LRC0402CJ22NGV001T

If you'd like the CAD PCB layout or have any questions,
 contact our application engineers at <https://www.johansontechnology.com/ask-a-question>

⁶ It is recommended that the designer leave available slots for a "pi" (shunt-series-shunt) network. The antenna matching network values above are used when the antenna is mounted on Johanson's evaluation board. The optimal matching values will vary depending on the layout, thickness, material, etc. Go to: <https://www.johansontechnology.com/tuning> for more information.

Evaluation Board Typical Return Loss Measurement (P/N 0433AT62A0020001CE1)

With Matching Network

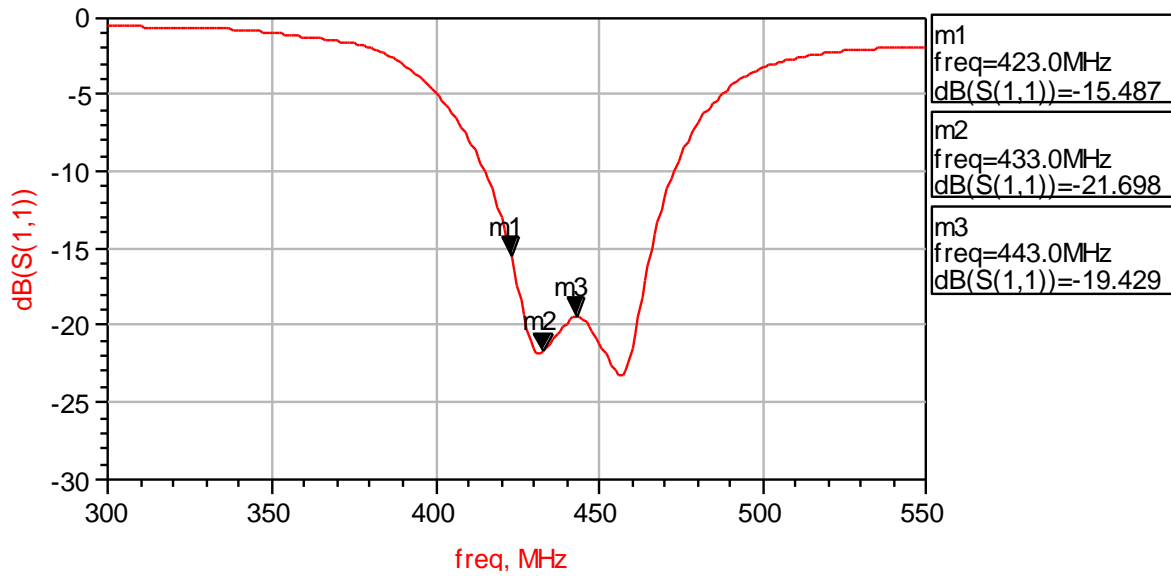

Evaluation Board 2D Radiation Patterns @433MHz (P/N 0433AT62A0020001CE1)

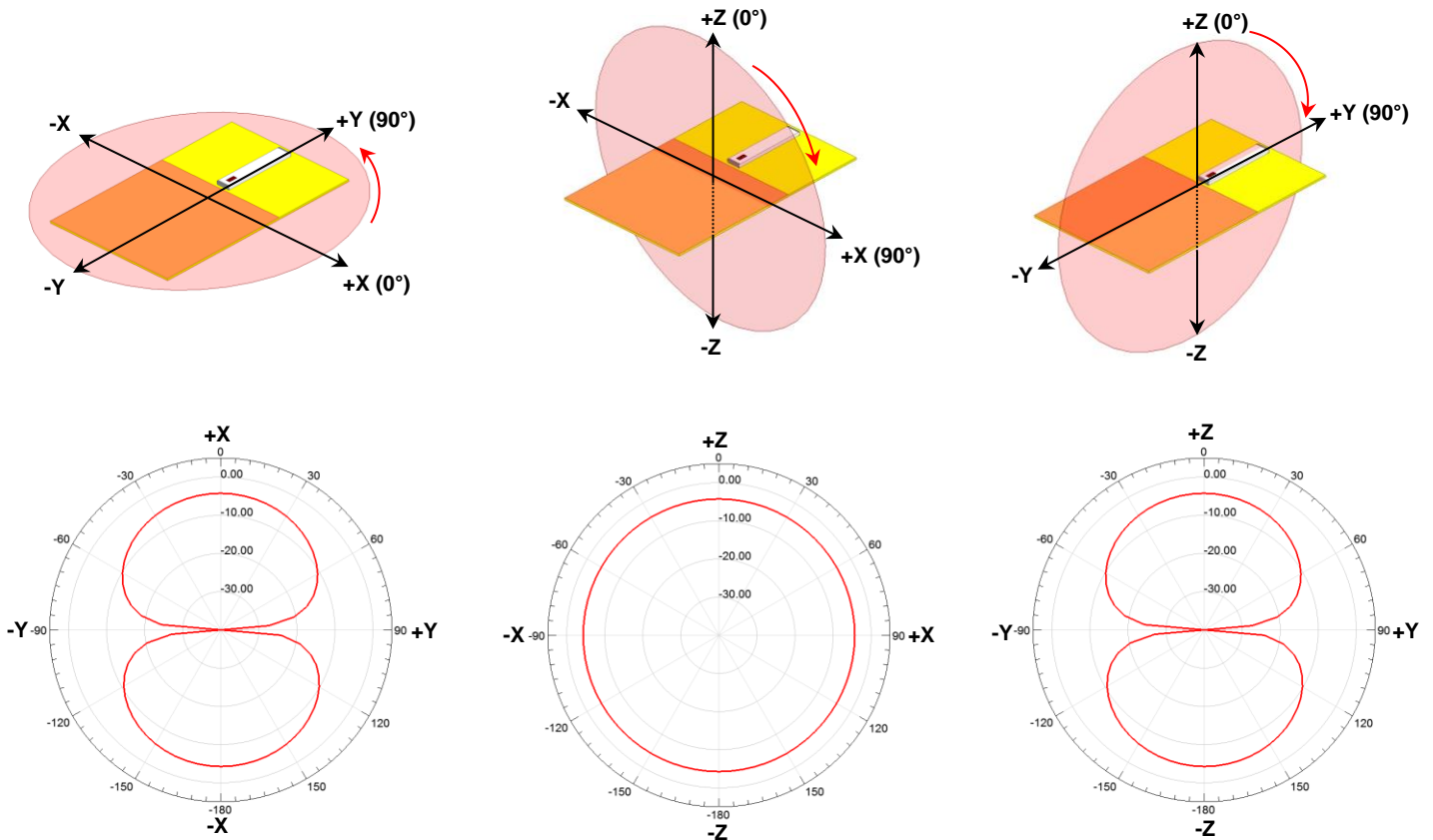

Evaluation Board and Recommended Mounting Configuration 2 (P/N 0433AT62A0020001CE4)

All units in mm

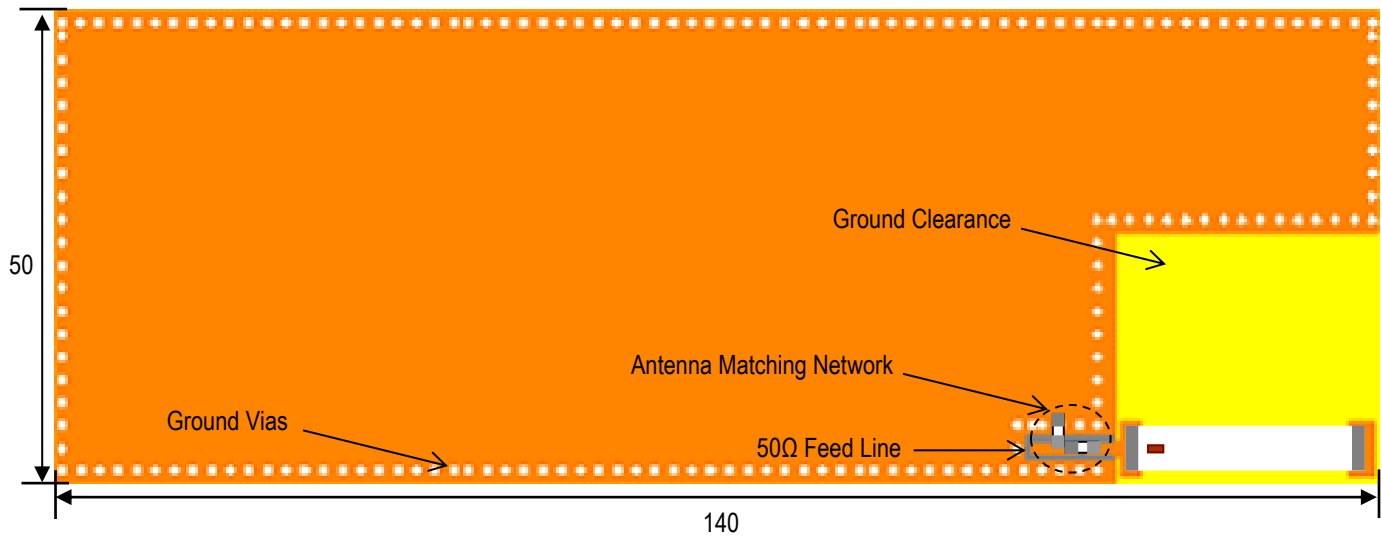

Solder Resist
 Land

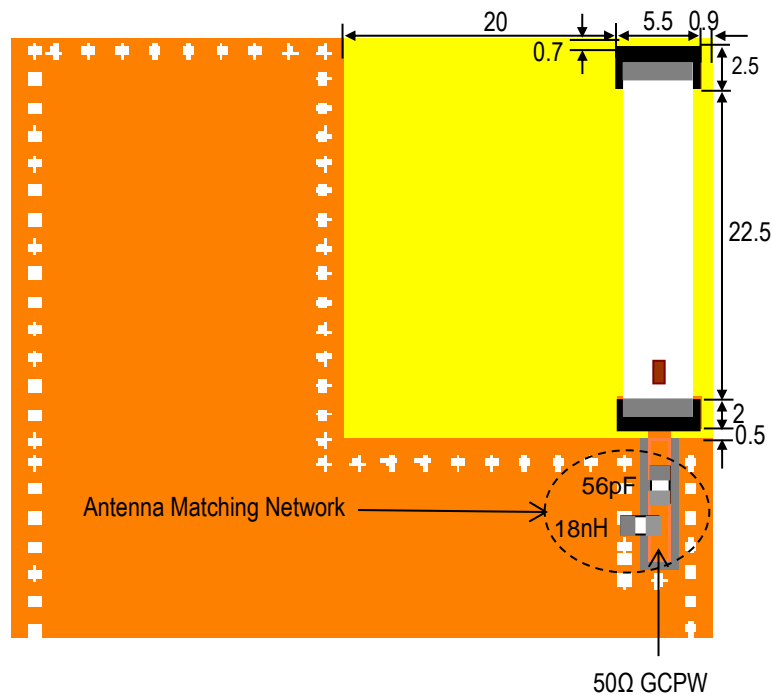

JTI P/N's for Matching Network⁷

Cap (56pF): QSCP251Q560J1GV001T

Inductor (18nH): LRC0603CJ18NGV001T

If you'd like the CAD PCB layout or have any questions, contact our application engineers at <https://www.johansontechnology.com/ask-a-question>.

⁷ It is recommended that the designer leave available slots for a "pi" (shunt-series-shunt) network. The antenna matching network values above are used when the antenna is mounted on Johanson's evaluation board. The optimal matching values will vary depending on the layout, thickness, material, etc. Go to: <https://www.johansontechnology.com/tuning> for more information.

Evaluation Board Typical Return Loss Measurement (P/N 0433AT62A0020001CE4)

With Matching Network

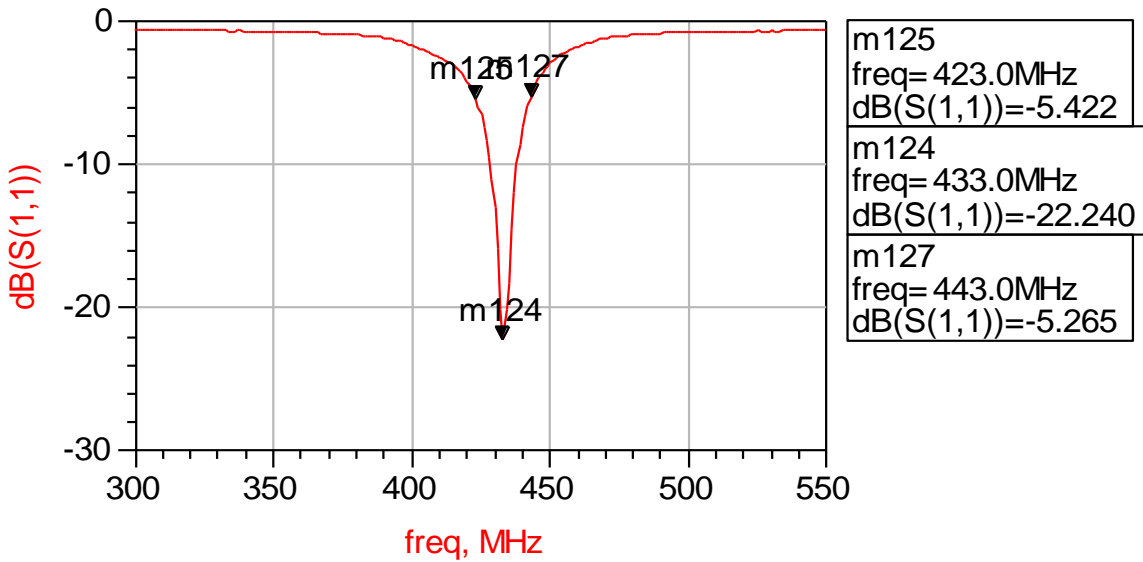

Evaluation Board 2D Radiation Patterns @433MHz (P/N 0433AT62A0020001CE4)

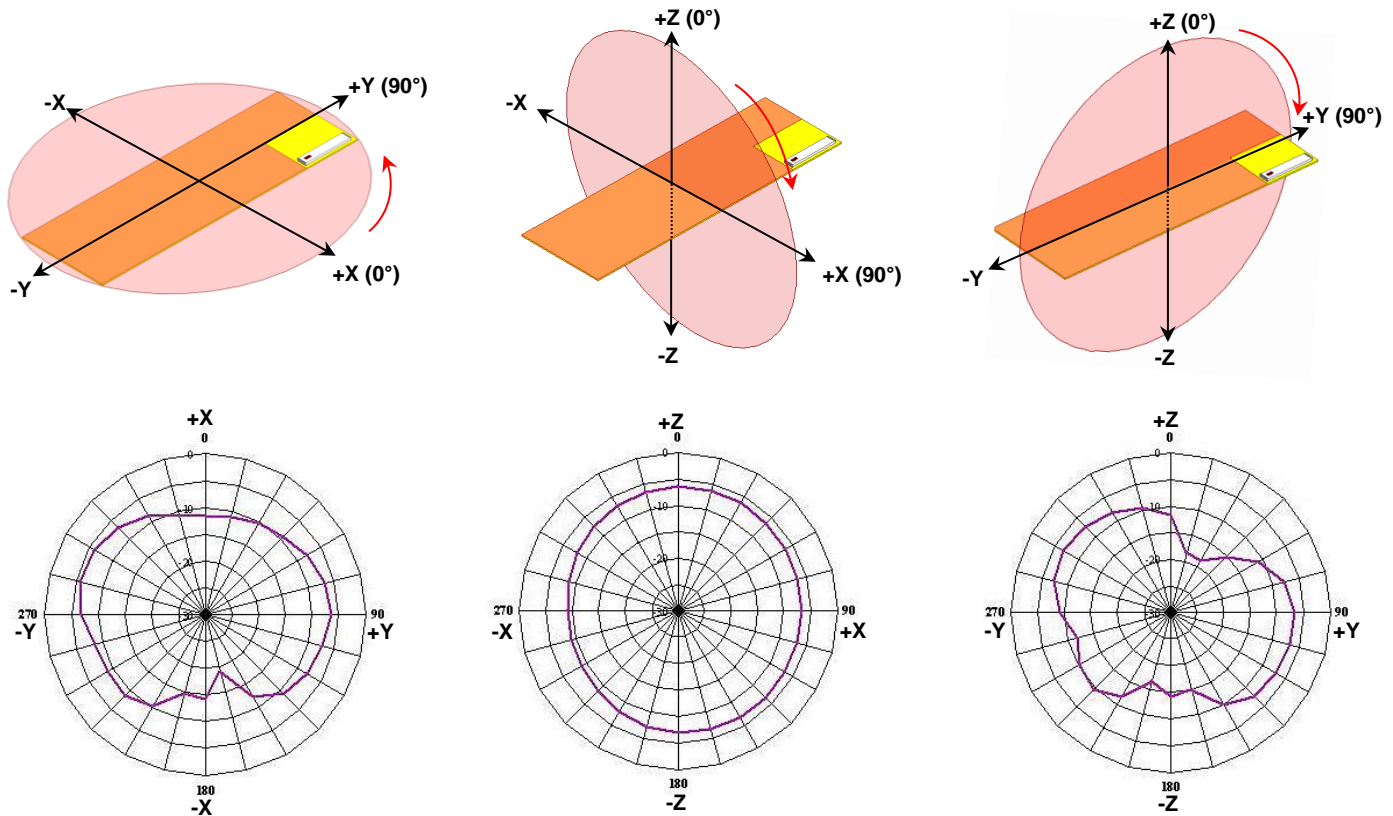

Evaluation Board Tuned @403MHz (P/N 0433AT62A0020001CE5)

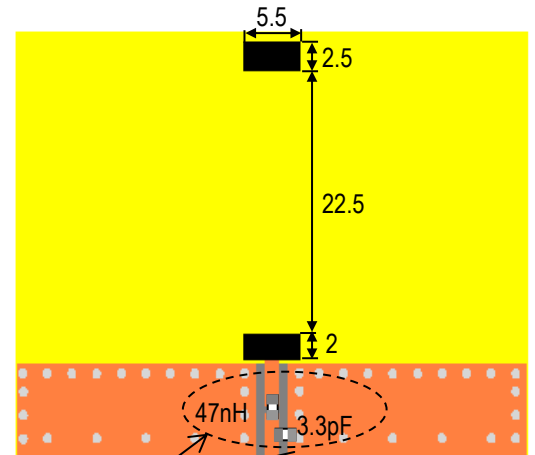
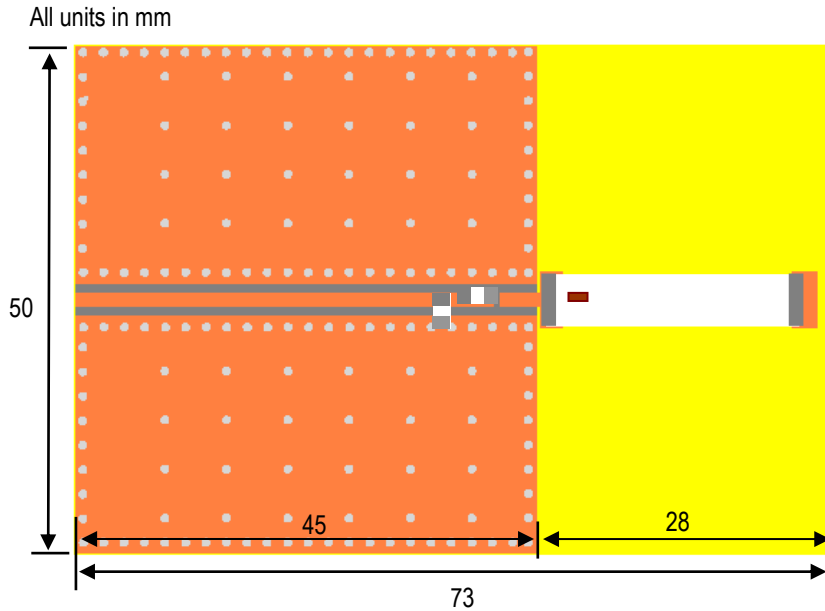

Antenna Matching Network 50Ω GCPW

 Solder Resist

 Land

JTI P/N's for Matching Network⁸

Inductor (47nH): LRC0402CJ47NGV001T

Cap (3.3pF): QSCF500Q3R3B1GV001T

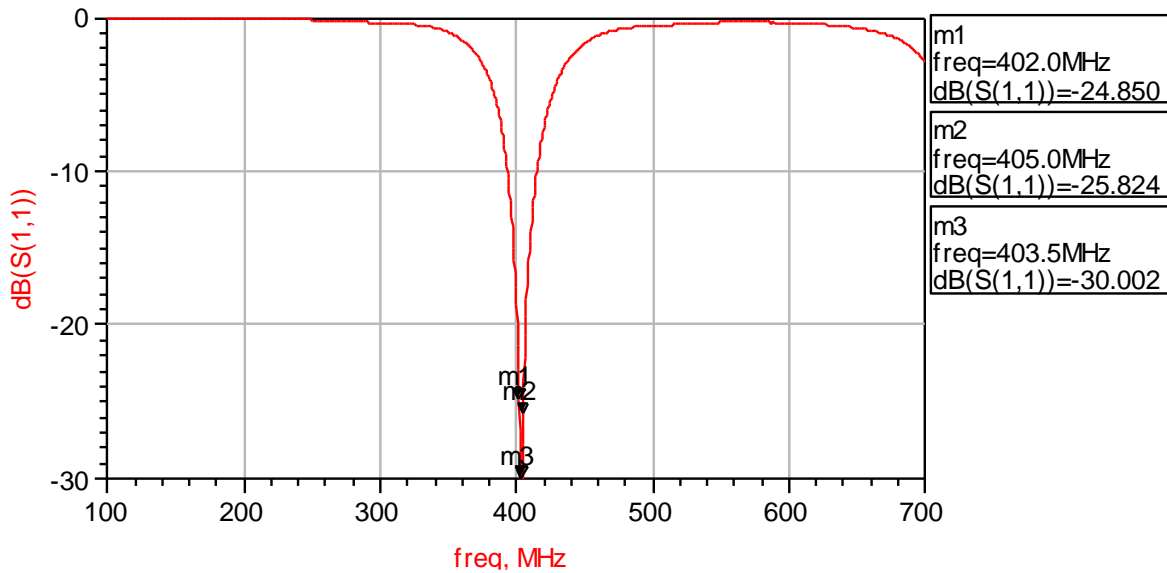

⁸ It is recommended that the designer leave available slots for a "pi" (shunt-series-shunt) network. The antenna matching network values above are used when the antenna is mounted on Johanson's evaluation board. The optimal matching values will vary depending on the layout, thickness, material, etc. Go to: <https://www.johansontechnology.com/tuning> for more information.

Evaluation Board Tuned @460MHz (P/N 0433AT62A0460001CE1)

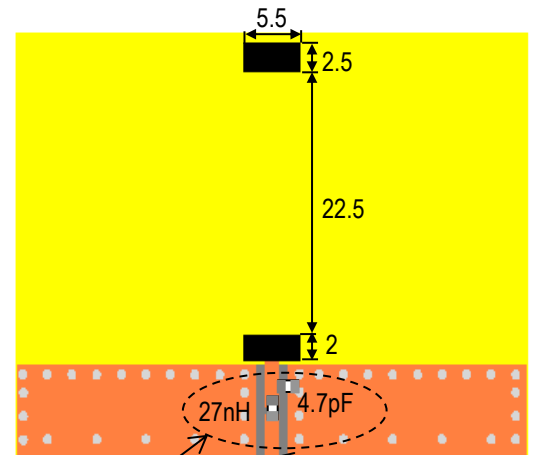
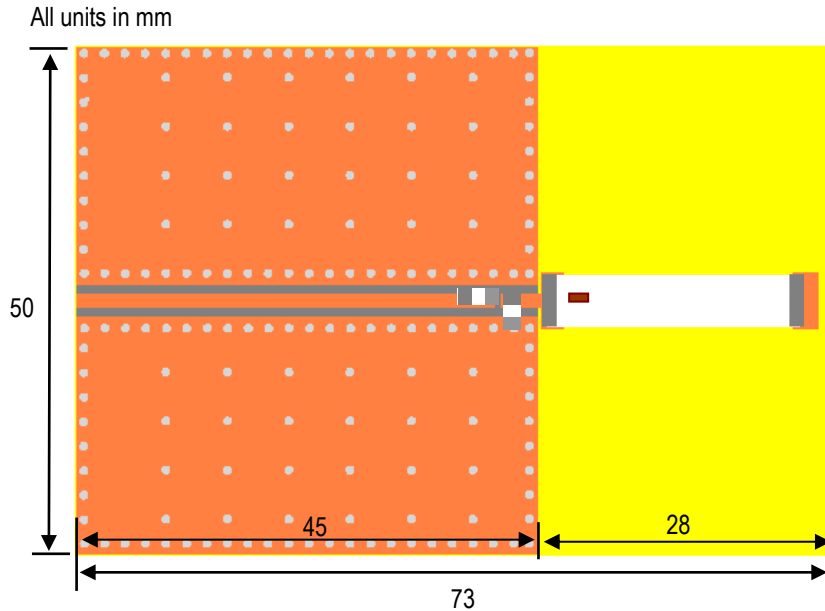

Antenna Matching Network 50Ω GCPW

■ Solder Resist

■ Land

JTI P/N's for Matching Network⁹

Cap (4.7pF): QSCF500Q4R7B1GV001T

Inductor (27nH): LRC0402CJ27NGV001T

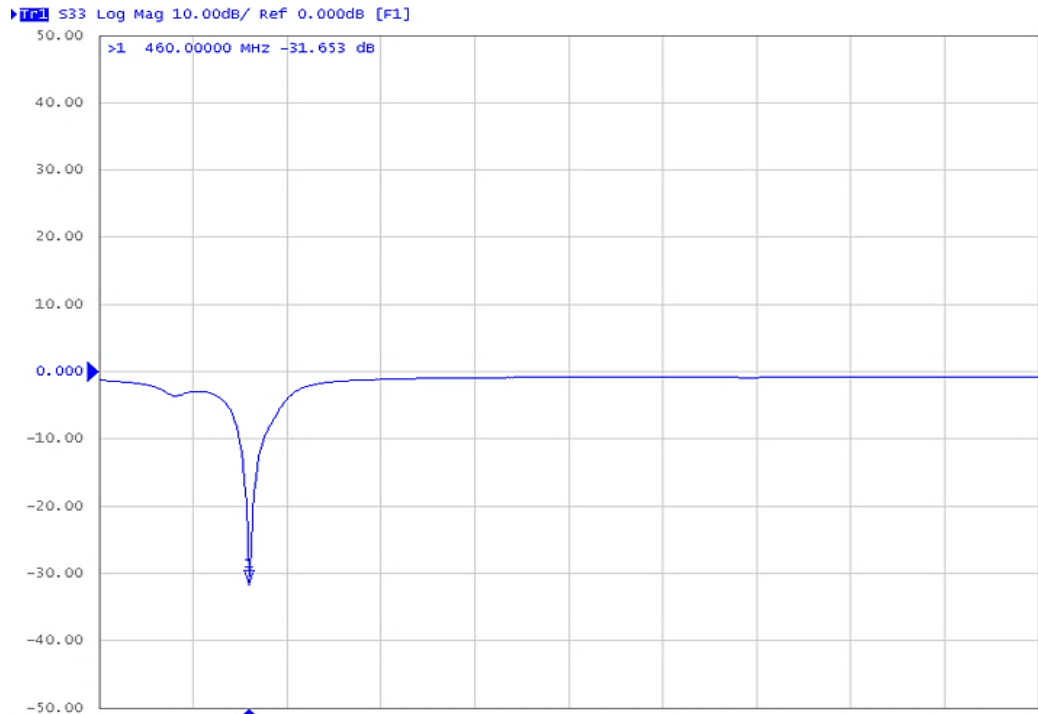

⁹ It is recommended that the designer leave available slots for a "pi" (shunt-series-shunt) network. The antenna matching network values above are used when the antenna is mounted on Johanson's evaluation board. The optimal matching values will vary depending on the layout, thickness, material, etc. Go to: <https://www.johansontechnology.com/tuning> for more information.

Tape and Reel Specification (Units in mm)

Tape Dimensions

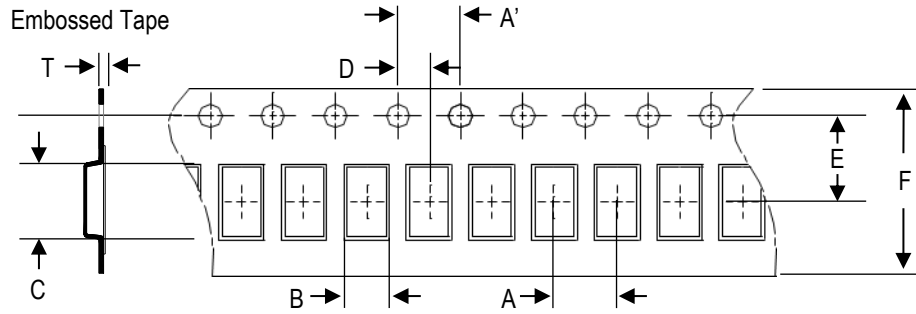

A	A'	B	C	D	E	F	T	Quantity/reel	Tape material
12.0±0.1	4.0±0.1	5.35±0.1	25.4±0.1	2.0±0.1	20.2±0.1	44.0±0.3	1.4±0.1	500pcs	Plastic (Embossed)

Reel Dimensions

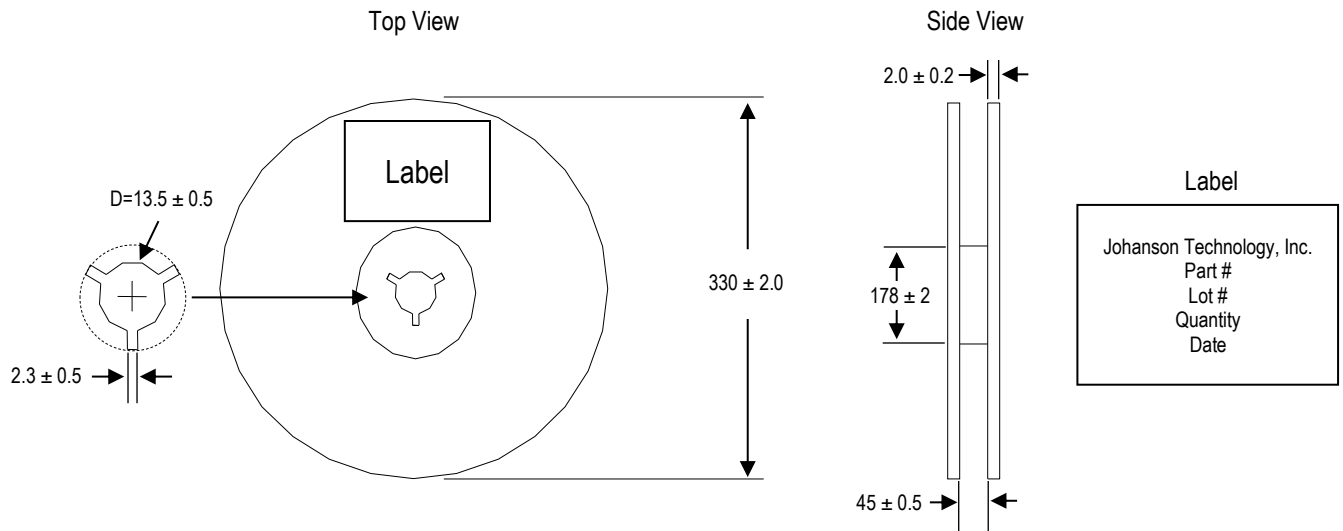

Leader and Trailer Dimensions

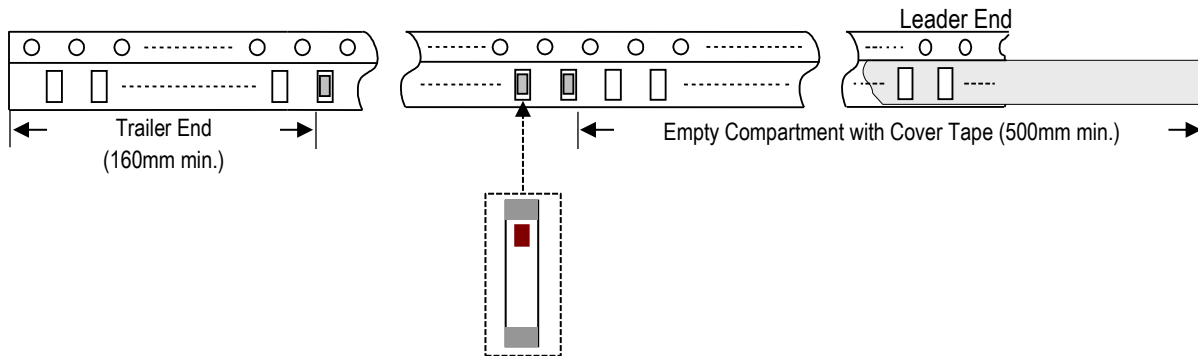

Orderable Part Number

Packaging Style	Part Number	Termination
Bulk (loose pcs.)	0433AT62A0020002B	Nickel Tin
T & R (13" Reel Embossed Tape)	0433AT62A0020002U (Qty: 500 pcs/reel)	
Evaluation Board with 1 SMA Connector	0433AT62A0020001CE1 (Page 3)	
	0433AT62A0020001CE4 (Page 5)	
	0433AT62A0020001CE5 (Page 7)	
	0433AT62A0460001CE1 (Page 8)	

Important Links

[0433AT62A0020002U Product Page](#)

[More Chip Antennas](#)

[Antenna Tuning, Optimization, and Validation Services](#)

[Soldering Information](#)

[MSL Information](#)

[Packaging Information](#)

[Recommended Storage Condition and Max Shelf Life](#)

[RoHS Compliance](#)

Contact our application engineers for a PCB layout review

**Johanson Technology, Inc. reserves the right to make design changes without notice.
All sales are subject to Johanson Technology, Inc. terms and conditions.**