

**Johanson Technology, Inc. 2450BM14A0002 Matched Balun for the
Nordic nRF24L01/nRF24L01+ Chipsets**

November 2009

1. Introduction

The nRF24L01/nRF24L01+ from Nordic Semiconductor is a 2.45GHz one chip, ultra low power transceiver.

Johanson Technology's, 2450BM14A0002 LPF-Balun was specifically designed for use with the nRF24L01/nRF24L01+ chipsets. This matched balun greatly simplifies the RF front-end by considerably reducing component count, system variability, implementation size area, and PCB sensitivity.

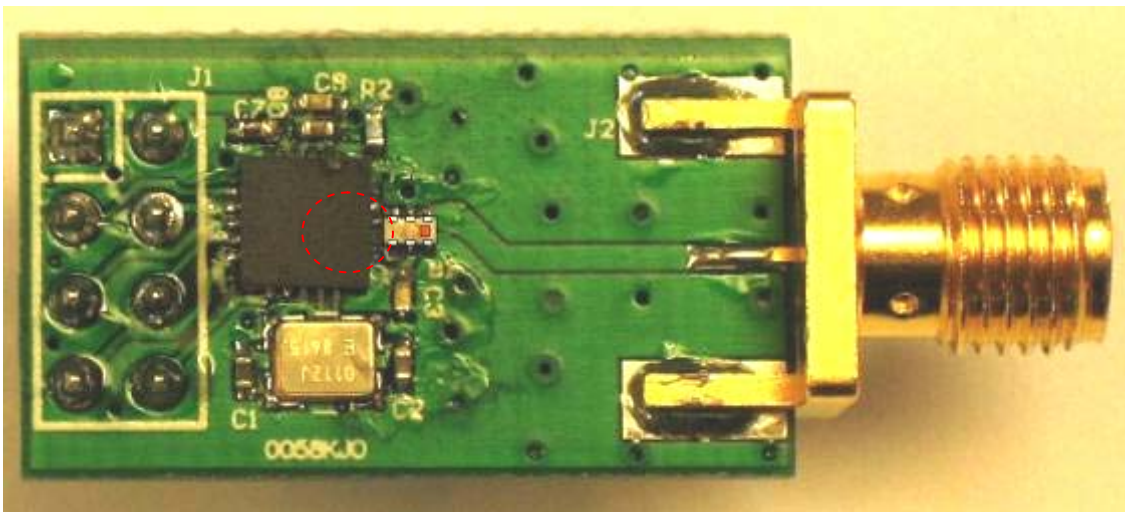

Figure 1. Component picture.

The 2450BM14A0002 is an SMD six-pin LTCC device with a small foot print of only 1.6 mm x 0.8 mm (EIA 0603).

2. Description of the Reference Design

Johanson Technology has developed a solution with a chip Balun-Harmonic filter integrated passive component that is especially matched for the nRF24L01/nRF24L01+ ICs, the 2450BM15A0002, shown in Figure 1.

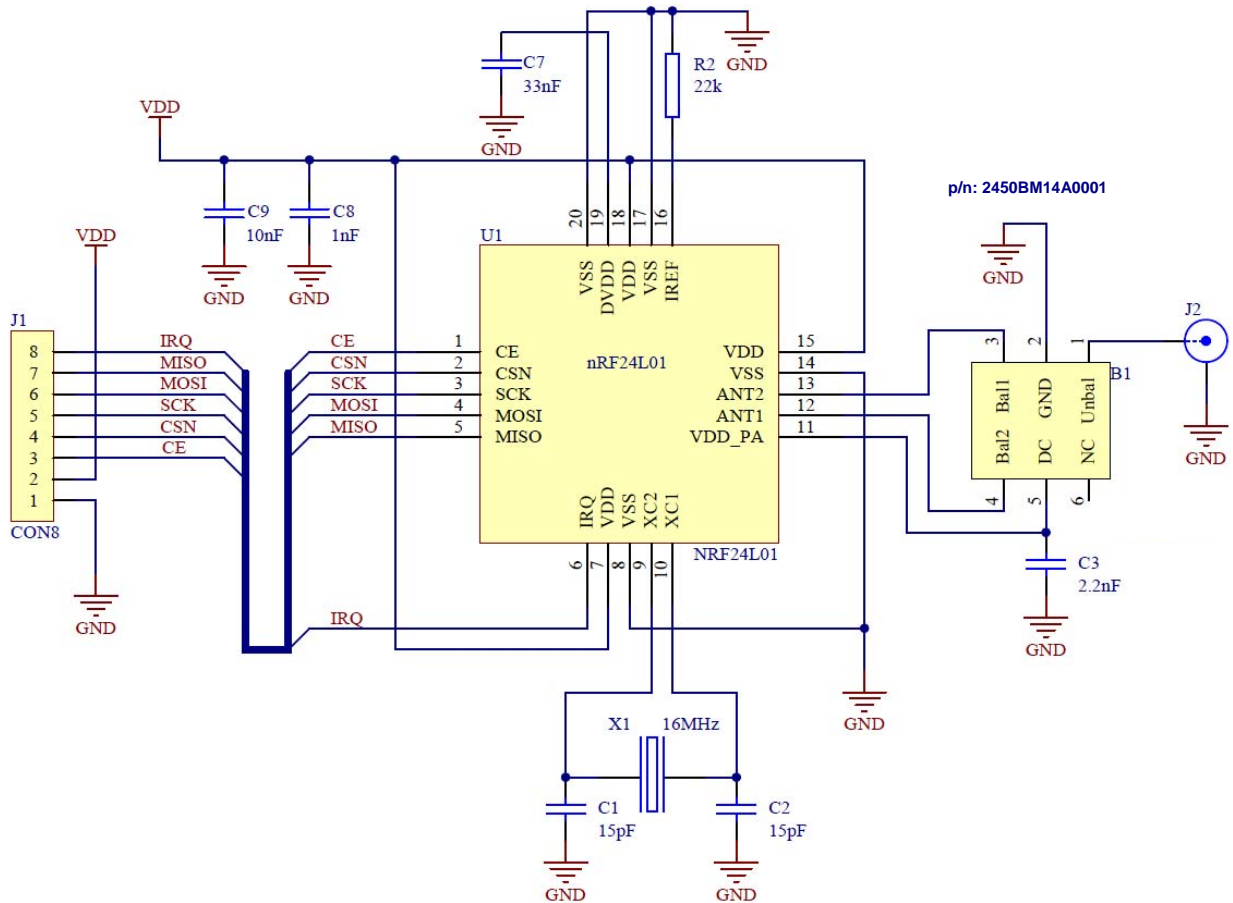

Figure 2. Integrated Reference Design

The rightmost is the JTI matched balun 2450BM14A0002.

Please refer to Appendix A for the datasheet of the balun filter component. For more updated information from the Johanson Technology web site at:

<http://johansontechnology.com/en/integrated-passives/chipset-specific-baluns.html>

The traditional reference design for RF balun has been the discrete solution shown in Figure 2.

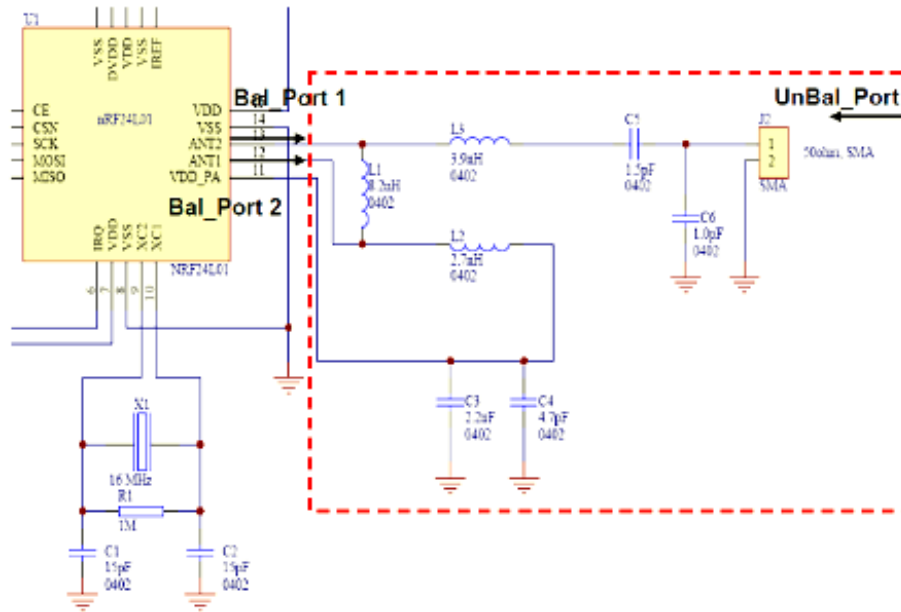

Figure 2. Discrete Reference Design

3. Layout

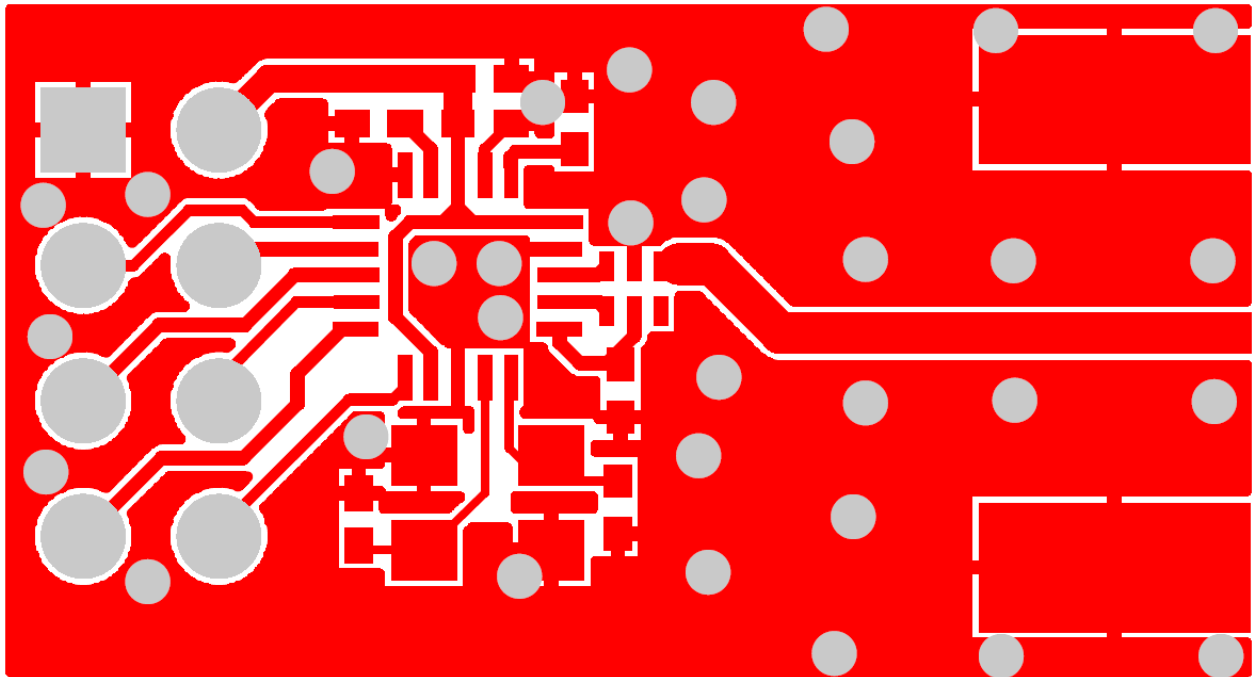

Figure 3. Layer 1 of the Reference Design Layout

In the event that the reference design can not be copied, then the routing from the RF pins ANT1 and ANT2 must be symmetrical to the matched balun component, 2450BM14A0002. The length of the tracks should be kept to a minimum and preferably the same length and width that are used in the reference design. If this routing is not symmetrical, then the output power may be reduced and the harmonics may increase.

The component placement influences the RF performance. It is recommended that the reference PCB layout be copied as closely as possible. In particular, the designer should make note of all dimensions between the nRF24L01/nRF24L01+ and 2450BM14A0002.

4. Measurement Results

All results presented in this chapter are based on measurements performed with nRF24L01/nRF24L01+ and 2450BM14A0002 Reference Design board. All measurement results presented are the average of each batch tested from typical devices.

Johanson's 2450BM14A0002 Harmonic Filter - Balun offers improved suppressed 2nd and 3rd harmonics, it eases implementation and increases margin to FCC/ETSI compliance when compared to solution with discrete passives.

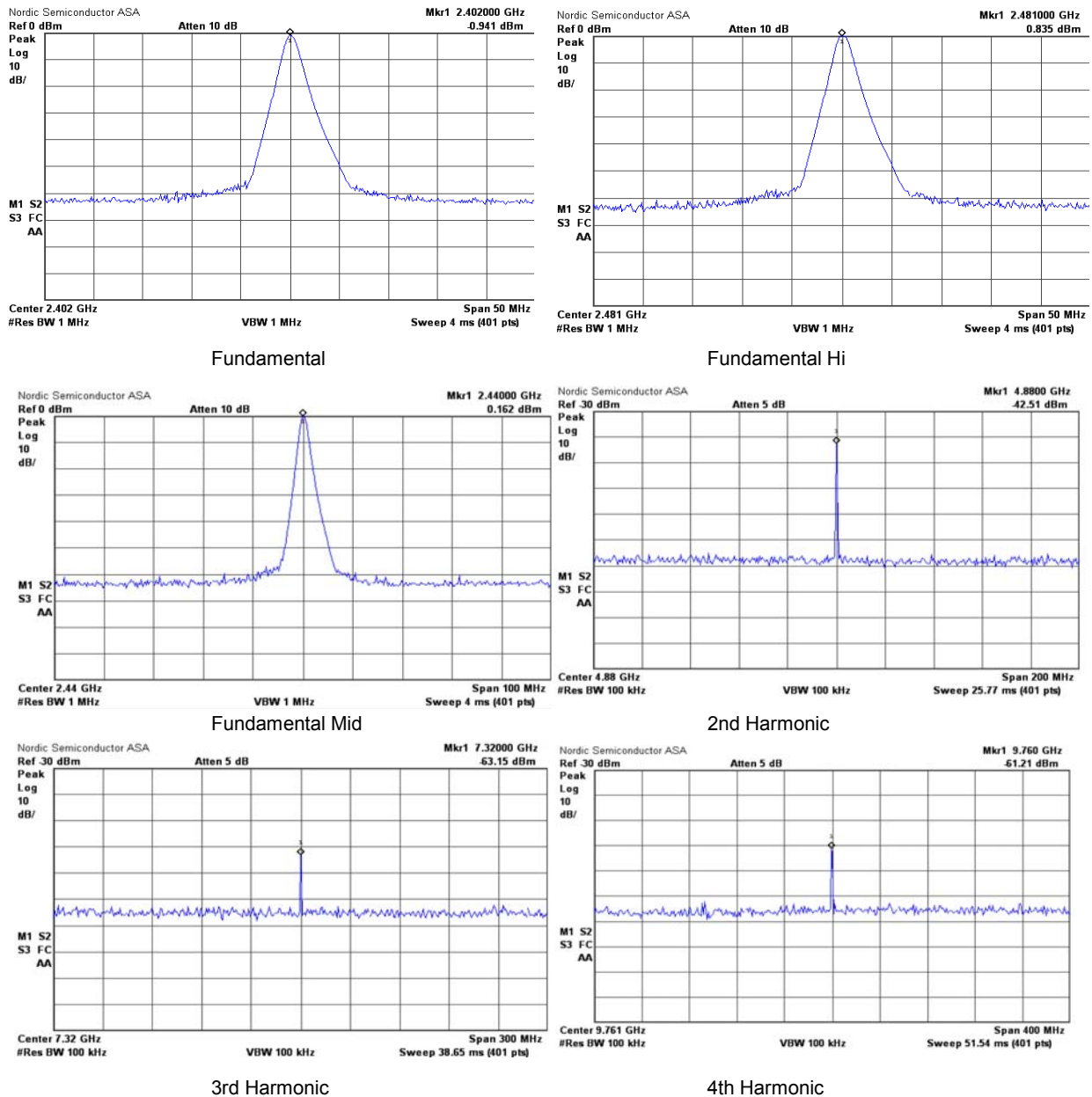
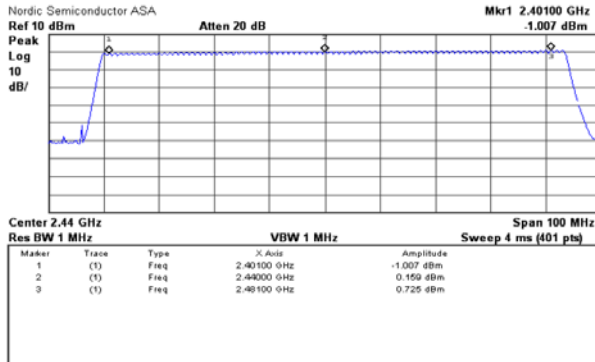
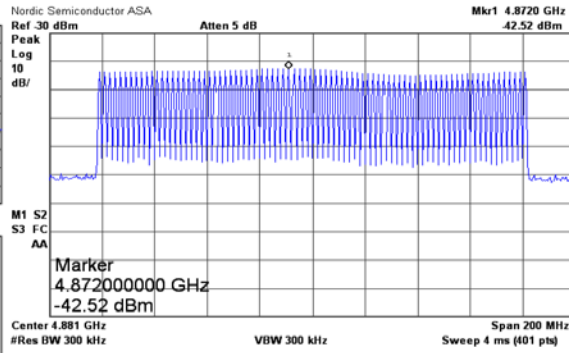

Figure 4. Active Measurement Results



Carrier Sweep



2nd Harmonic Sweep

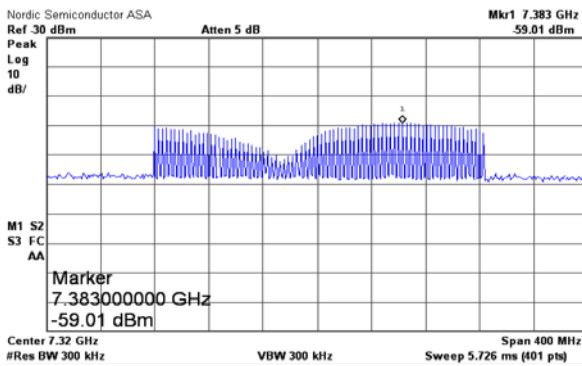

3rd Harmonic Sweep

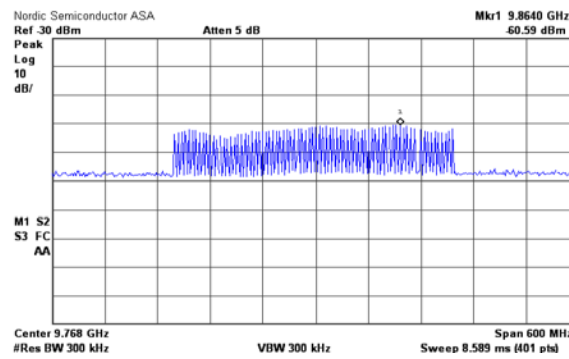

4th Harmonic Sweep

Figure 5. Sweep Measurement Results

Appendix A

High Frequency Ceramic Solutions

2.45 GHz Impedance Matched Balun-Filter: Optimized for Nordic's Chipset nRF24L01/+

P/N 2450BM14A0002

Detail Specification: 11/12/10

Page 1 of 2

General Specifications

| | |
|--|--|
| Part Number | 2450BM14A0002 |
| Frequency (MHz) | 2400 - 2500 |
| Unbalanced Impedance | 50 Ω |
| Differential Balanced Impedance | Conjugate match to Nordic nRF24L01/nRF24L01+ |
| Attenuation: Differential Mode | 15 min. @4800~5000MHz 15 min. @7200~7500MHz |
| Attenuation: Common Mode | 20 min. @4800~5000MHz |

| | |
|------------------------------|---|
| Insertion Loss | 2.0 dB max. |
| Return Loss | 9.5 dB min. |
| Phase Difference | 160° ± 15° |
| Amplitude Difference | 3.5 ± 1.5 dB |
| Reel Quantity | 4,000 |
| Operating Temperature | -40 to +85°C |
| Storage Temperature | +5 to +35°C, Humidity: 45-75%RH, 12 mos. Max |

| | | | | |
|-------------------|--------------------------|------------|------------------------|---------------------------|
| P/N Suffix | Packaging Style | Bulk | Suffix = S | Eg. 2450BM14A0002S |
| | | T & R | Suffix = E | Eg. 2450BM14A0002E |
| | Termination Style | 100% Tin | Suffix = None | Eg. 2450BM14A0002(E or S) |
| | | Tin / Lead | Please consult Factory | |

Terminal Configuration

| No. | Function |
|-----|-----------------------|
| 1 | Unbalanced Port |
| 2 | GND |
| 3 | Balanced Port |
| 4 | Balanced Port |
| 5 | DC Feed+RF GND or GND |
| 6 | NC |

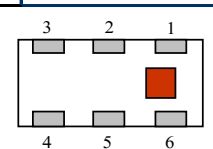

Mechanical Dimensions

| | In | mm |
|----------|--------------------|-----------------|
| L | 0.063 ± 0.004 | 1.60 ± 0.10 |
| W | 0.031 ± 0.004 | 0.80 ± 0.10 |
| T | 0.024 ± 0.004 | 0.60 ± 0.10 |
| a | 0.008 ± 0.004 | 0.20 ± 0.10 |
| b | 0.008 +.004/-0.006 | 0.20 +0.1/-0.15 |
| c | 0.006 ± 0.004 | 0.15 ± 0.10 |
| g | 0.012 ± 0.004 | 0.30 ± 0.10 |
| p | 0.020 ± 0.002 | 0.50 ± 0.05 |

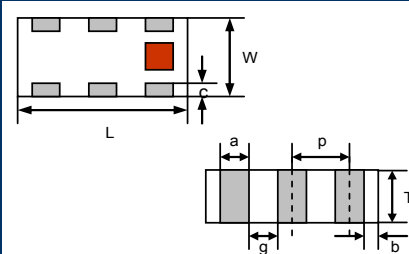

Mounting Considerations

Mount these devices with maroon mark facing up.

* Line width should be designed to provide 50 Ω impedance matching characteristics.

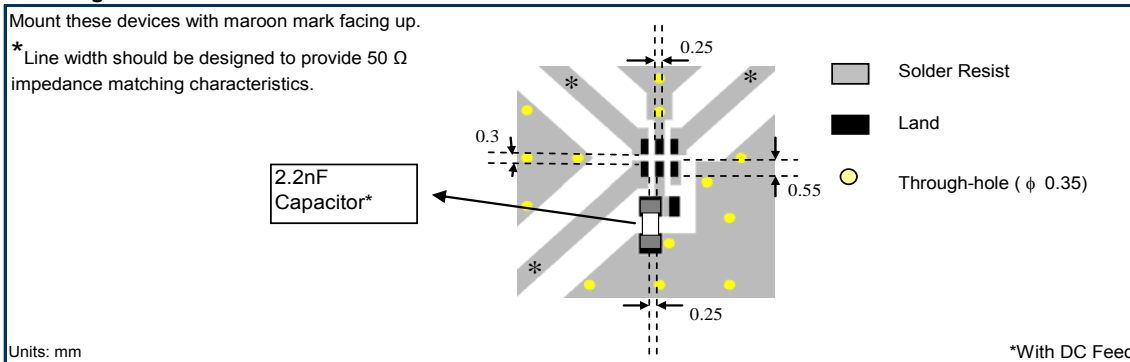

Johanson Technology, Inc. reserves the right to make design changes without notice.

The latest specification can be downloaded from the following link:

<http://johansontechnology.com/en/integrated-passives/chipset-specific-baluns.html>

www.johansontechnology.com

High Frequency Ceramic Solutions

2.45 GHz Impedance Matched Balun-Filter: Optimized for Nordic's Chipset nRF24L01/+ P/N 2450BM14A0002
 Detail Specification: 11/12/10 Page 2 of 2

Typical Electrical Performance (T=25°C)

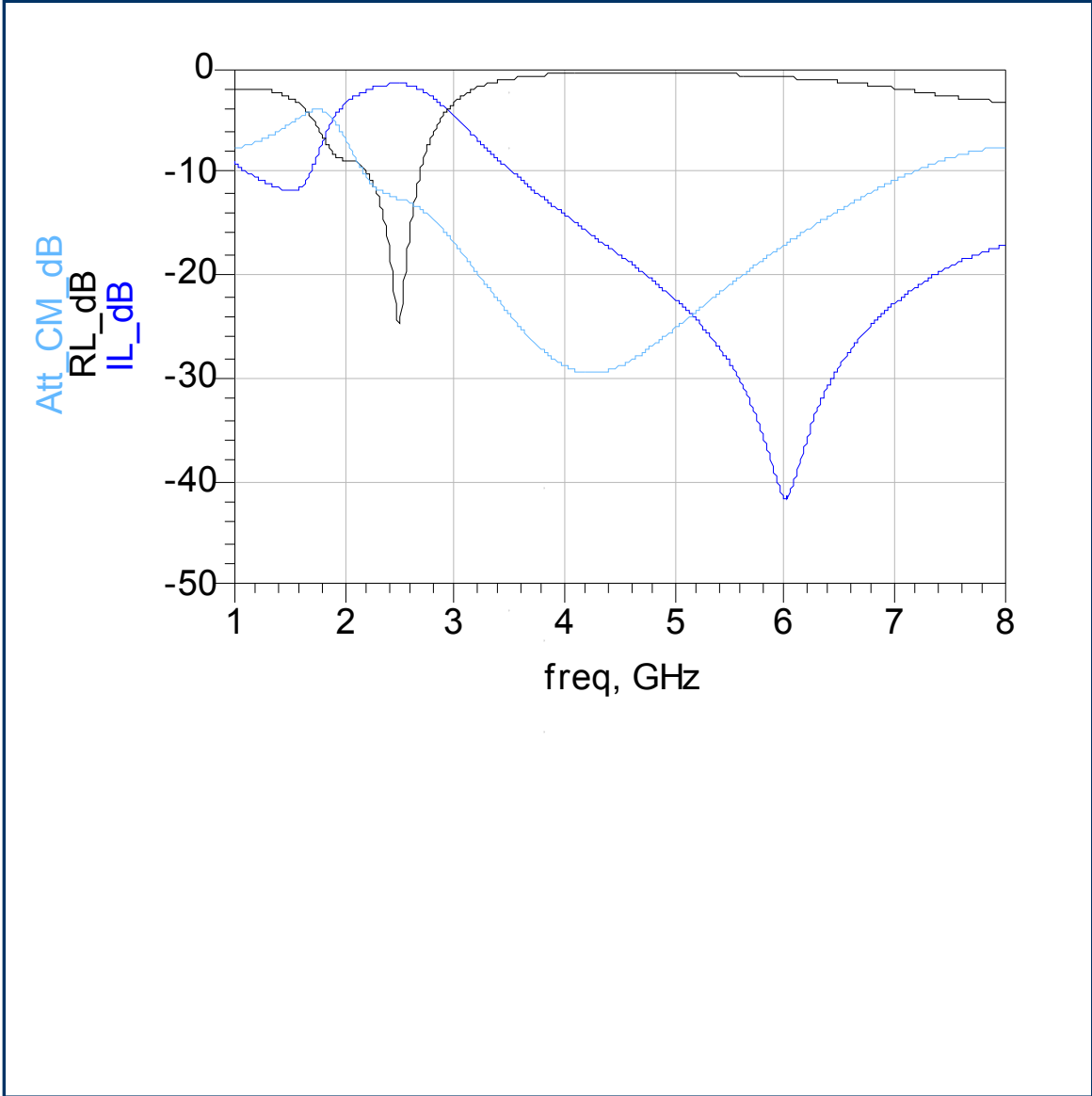

Johanson Technology, Inc. reserves the right to make design changes without notice.
 All sales are subject to Johanson Technology, Inc. terms and conditions.

The latest specification can be downloaded from the following link:
<http://johansontechnology.com/en/integrated-passives/chipset-specific-baluns.html>